

# ZUCCHINI

## XCP Busbar Trunking Systems

Installation and user manual

LE12461AA-02GF-25W41



## XCP Busbar Trunking Systems

EN

ENGLISH

3



## General information

The information in this installation manual offers general descriptions and takes into account the general technical features of the products discussed, with the object of guiding the user through the installation of the XCP busbar. Therefore, product reliability for specific user applications cannot rely on this manual to ensure suitability or reliability of the busbar.

Each user must assess the specific risks and test the product based on their own specific application. Neither Legrand, nor any of its subsidiaries or controlled companies shall be held responsible for the improper use of the information contained in this document.

For any suggestions of any kind regarding this manual, please contact Legrand directly.

The user hereby agrees not to reproduce this manual in full or in part for commercial use, or for any other use that is not strictly personal.

The reproduction of this manual is also prohibited, on any supports whatsoever, including multimedia or internet publication, without the explicit written consent of Legrand.

The publication of any types of hyperlinks to this manual or part thereof is also strictly prohibited.

The user of this manual agrees to use it exactly as it is written, and always at their own risk.

Only the manufacturer has the authority of intervening on individual components for replacement and repair purposes, in order to ensure the compliance of those described in this document.

The instructions of this manual must always be followed, to ensure correct installation of the components within the system.

Failure to comply with such instructions can cause injury or damage to system components and equipment.



### **Safety instructions**

This product should be installed in compliance with installation rules, preferably by a qualified electrician. Incorrect installation and/or incorrect use can lead to risk of electric shock or fire.

Before carrying out the installation, read the instructions and take account of the product's specific mounting location.

Do not open up, dismantle, alter or modify the device except where specifically required to do so by the instructions.

All Legrand products must be opened and repaired exclusively by personnel trained and approved by Legrand. Any unauthorised opening or repair completely cancels all liabilities and the rights to replacement and guarantees.

Use only Legrand brand accessories.

# ZUCCHINI

---

## Index

<b>1. Introduction</b>	<b>6</b>
1.1 Safety Information	6
1.1.1 Important Information	6
1.2 Safety tips	7
1.3 Purpose of the document	7
1.4 Product overview	8
1.4.1 Straight elements	8
1.4.2 Additional elements	8
1.4.3 Angle components	8
1.4.4 Tap-off boxes	9
1.4.5 Connection interfaces	9
1.4.6 Fixing supports	9
<b>2. Material preparation and arrangement</b>	<b>10</b>
2.1 Equipment and Tools	10
2.1.1 Introduction	10
2.1.2 Lifting and handling equipment	10
2.1.3 Supports for positioning and installing	10
2.2 Storage	11
2.3 Weight table	12
2.4 Handling and lifting	14
2.5 Missing or damaged components	17
2.6 Product type identification	18
<b>3. Installation</b>	<b>20</b>
3.1 Checks before installation	20
3.1.1 Visual / electric checks	20
3.1.2 General rules for installing supports	20
3.1.3 Fixing accessories	21
3.2 Installation of wall supports	33
3.2.1 Installation sizes, distances and positioning logics	33
3.3 Detailed instructions for vertical installation	35
3.3.1 Charging definition in brackets with springs	36
3.3.2 Wall and floor drilling	38
3.3.2.1 Floor bracket with/without springs	39
3.3.2.2 Wall bracket with springs and anti-seismic bracket	40
3.3.2.3 Standard bracket	44
3.3.3 Attaching the brackets to the busbars	47
3.3.3.1 Floor bracket with springs	47
3.3.3.2 Floor bracket without springs	49
3.3.3.3 Wall bracket with springs	51
3.3.3.4 Wall bracket without springs	53
3.3.4 Busbar mounting in line	55
3.3.4.1 Floor bracket with/without springs	55
3.3.4.2 Wall bracket with springs and anti-seismic bracket	56
3.3.4.3 Standard bracket	57
3.3.5 Joint installation	58

---

---

3.3.6 Fire barrier installation	64
3.3.7 Panel end cap installation	66
3.3.8 End caps	72
<b>4. Comissioning</b>	<b>73</b>
<hr/>	
4.1 Busbar Pre-energising Checks	73
4.1.1 Busbar Installation	73
4.1.2 Electrical Safety Tests	73
4.1.3 Electric Checks	73
4.2 Filling the check form	74
4.2.1 Busduct record form for inspections and controls	74
4.2.2 Inspections after installation	74
<b>5. Verification</b>	<b>75</b>
<hr/>	
5.1 Busbar Periodic Inspections	75
5.1.1 Inspection Actions	75
5.1.2 Busbar Periodic Inspections	75
5.2 Thermal and Visual Inspection of TOBs	75
5.2.1 Annual periodic inspections carried out one year after energizing and every other following year	76
5.2.2 Inspections after installation and yearly	77
5.2.3 Feeder element	78
5.2.4 Dihedral elbow	79
5.2.5 Flat elbow	80
5.2.6 Troubleshooting table	81
<b>6. Disposal</b>	<b>81</b>
<hr/>	

# ZUCCHINI

---

## 1. Introduction

### 1.1 Safety Information

#### 1.1.1 Important Information

Here above general information concerning with signalling to take into account for all operative phases of the installation. This symbology and these messages are used all through the manual in order to highlight any potential dangerous situations or to arouse attention to procedures.



The addition of symbol to a "Danger" or "Warning" safety label indicates that an electrical hazard exists which will result in personal injury if the instructions are not followed.



This is safety alert symbol. It is used to alert you to potential personal injury hazards. Obey all safety messages that follow this symbol to avoid possible injury or death.



#### **DANGER**

DANGER indicates a hazardous situation which, if not avoided, **will result in** death or serious injury.



#### **WARNING**

WARNING indicates a hazardous situation which, if not avoided, **could result in** death or serious injury.



#### **CAUTION**

CAUTION indicates a hazardous situation which, if not avoided, **could result in** minor or moderate injury.

#### **NOTICE**

NOTICE is used to address practices not related to physical injury.

#### **PLEASE NOTE**

Electrical equipment should be installed, operated, serviced, and verified only by qualified personnel.

No responsibility is assumed by Legrand for any consequences arising out of the use of this material.

A qualified person is one who has skills and knowledge related to the construction and operation of electrical equipment and its installation, and has received safety training to recognize and avoid the hazards involved.

## 1.2 Safety tips



**WARNING**

### HAZARD OF CRUSHING AND FRACTURES

- Wear personal protective equipment when handling and installing the products (long sleeved jacket, trousers, gloves, safety shoes, helmet, and safety glasses).
- Only personnel who have been trained in safety regulations may work on construction sites to install busbar trunking systems.
- Work with extreme caution and follow the instructions provided in the manual.

Failure to follow these instructions can result in death, serious injury, or equipment damage.



## 1.3 Purpose of the document

The present manual contains all the information necessary for the installation of Legrand XCP busbar trunking system (Xtra Compact busbar).

It contains the rules and procedures to be taken into account during the different phases involved in the whole process related to the realization of the plant and its final power up.

In particular all preliminary requirements, specific installation procedures and overall recommendations are explained along the present manual.

Topics exposed can be divided into different sections:

- check of the equipment and of all the tools necessary for plant assembly
- check of all the material availability and its correct identification (both as an individual component and inside the whole system)
- pre-installation checks on connections among different components
- detailed operative installation procedures

Also checks to be carried out after installation and before to power up (“comissioning”) are exposed in this manual

A final part related to the periodic checking of the plant during its life is also illustrated (with the definition of the types and frequency of the checks to be performed)

This manual is addressed to qualified technical personnel

# ZUCCHINI

## 1. Introduction

### 1.4 Product overview

#### 1.4.1 Straight elements

Supplied with its pre-installed monobloc.

##### Feeder elements:

- standard length: 3 m
- special length: from 0.5 m to 3 m

##### Distribution elements with tap-off outlets:

- standard length: 3 m
- standard tap-off sockets:  
spaced at 850 mm intervals on both sides

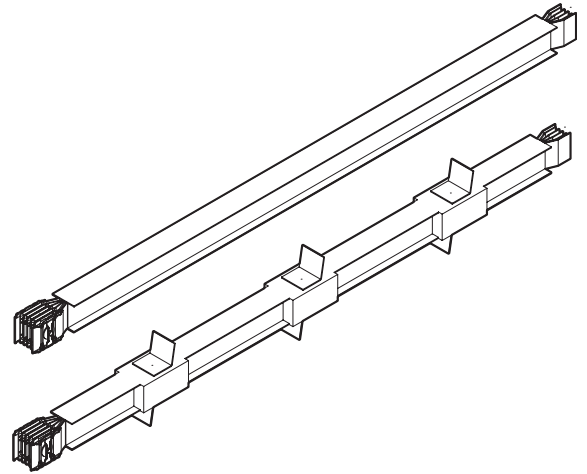

#### 1.4.2 Additional elements

Supplied with its pre-installed monobloc.  
Elements able to meet any installation requirement.

##### Elements with fire barrier

##### Elements with phase balancing

##### Elements with thermal expansion device

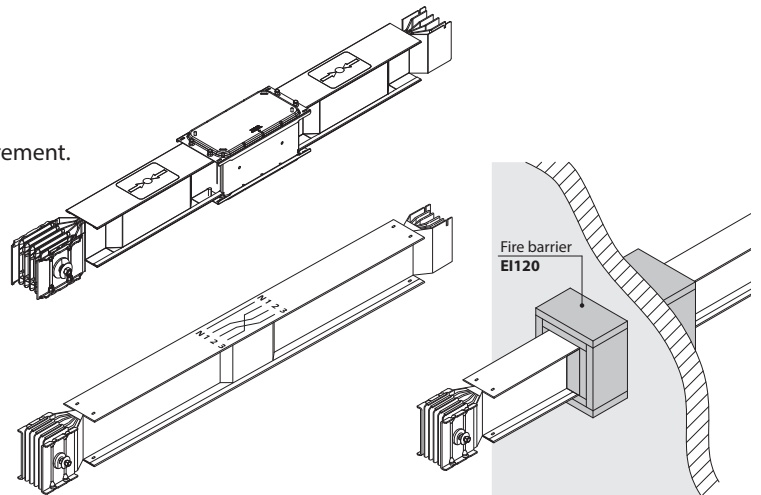

#### 1.4.3 Angle components

Supplied with its pre-installed monobloc.  
Elements able to meet any change of direction  
with standard or special solutions.

##### Elbows

##### Double elbows

##### Special T elements

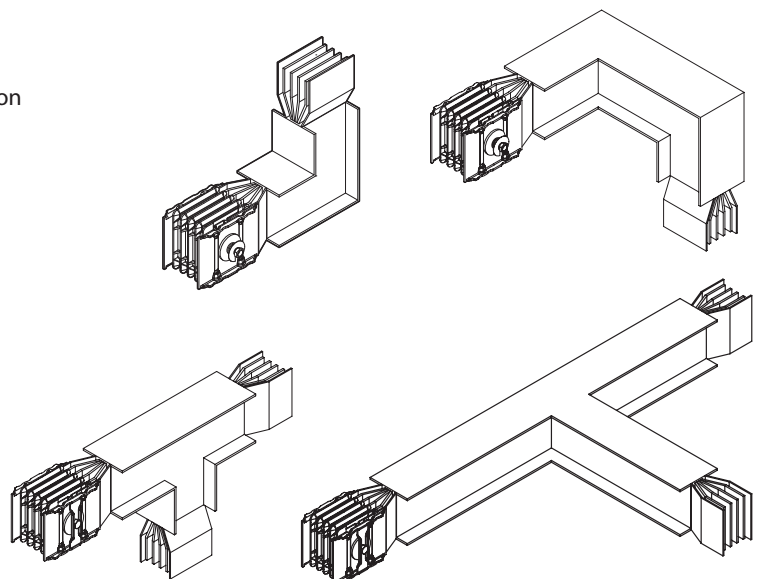



## 1.4.4 Tap-off boxes

Elements used for connecting and energizing electric loads.

### Plug-in tap-off boxes from 63 A up to 630 A: (can be installed with busbar energized)

- with 3P fuse holders
- with switch disconnecter and fuse holder
- for MCCB circuit breakers

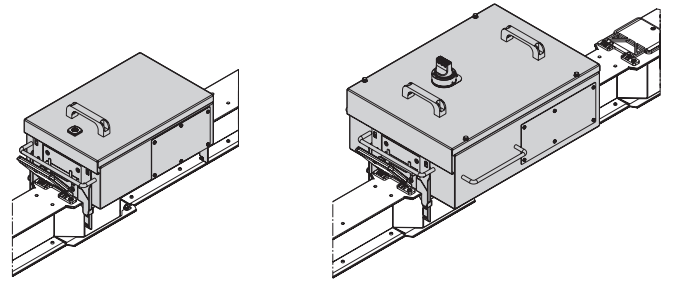

### TOB on the junction: type bolt-on from 125 A to 1250 A:

- with switch disconnecter and fuse holder
- for MCCB circuit breakers

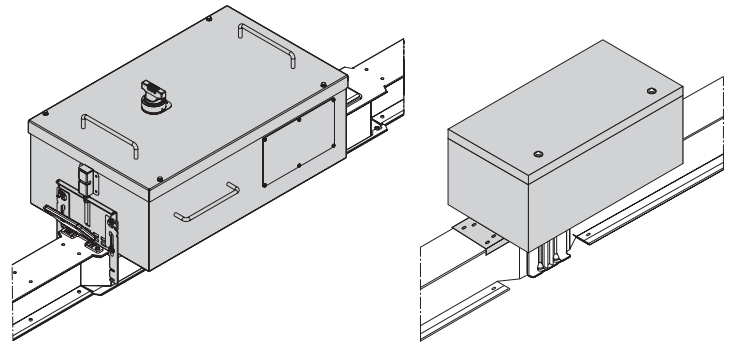

## 1.4.5 Connection interfaces

Elements used for connecting the busbar to the electric board or transformer.

### Solutions for Legrand XL<sup>3</sup> cabinets and Legrand cast resin transformers Universal solutions

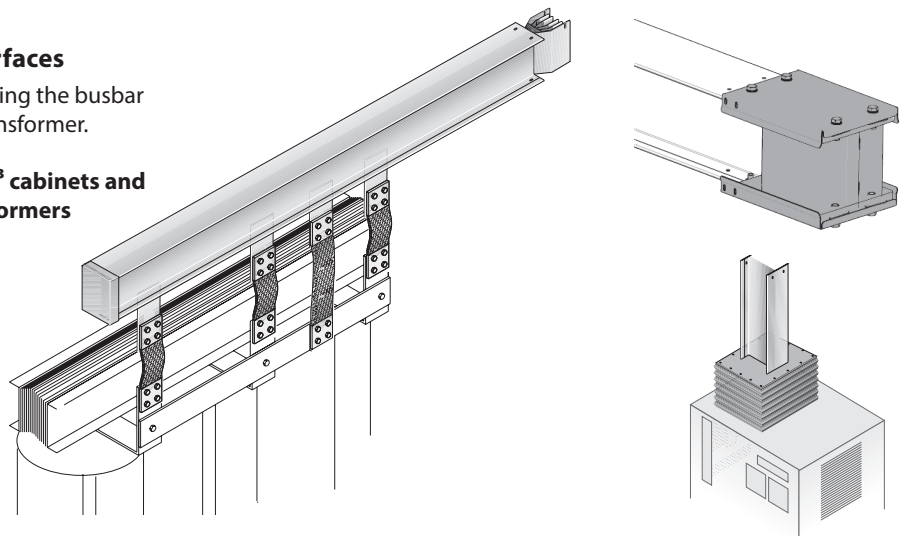

## 1.4.6 Fixing supports

Elements used for fixing the busbar to the structure of the building.

### Options for horizontal installations Options for vertical installations Options for special applications (seismic zones, naval environment)

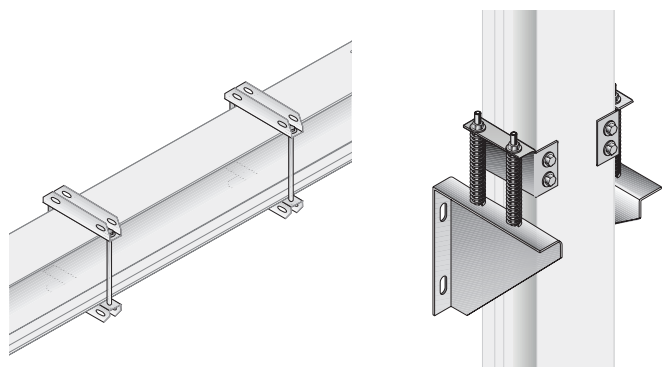

# ZUCCHINI

---

## 2. Material preparation and arrangement

### 2.1 Equipment and Tools

#### 2.1.1 Introduction

Here below the tools, equipment and materials necessary you need to have before to start the installation of Zucchini XCP Busbar Trunking System.

#### 2.1.2 Lifting and handling equipment

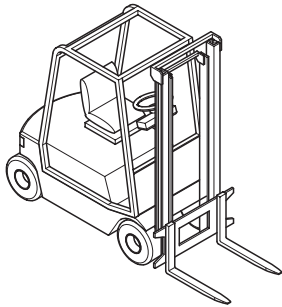

Crane or forklift truck capable of lifting 1.5 tons (minimum). In function of the plant and the typology of components.

#### 2.1.3 Supports for positioning and installing

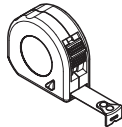

Measuring tape (metric).

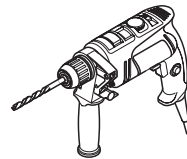

Drilling machine capable of drilling through concrete.

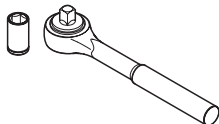

Socket wrench with sockets (8...24 mm).



Set of flat or ring spanners (8...24 mm).



Two slings for handling the components.

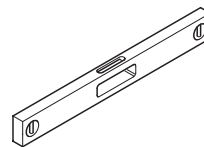

Levelling instrument (spirit level).

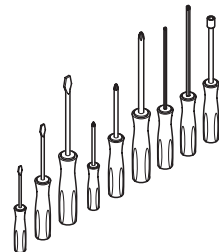

Set of screwdrivers.

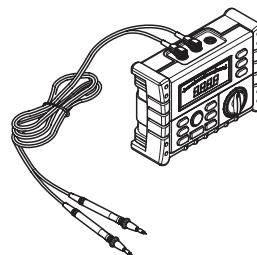

Insulation tester (Megohmmeter 1000 Vdc).



Carpenter's square.

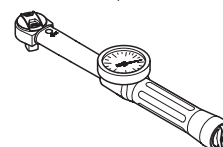

Torque wrench.

**2.2 Storage**

Below are the instructions to follow for a correct storage of the materials.  
Failure to comply with the indications supplied may cause damage to the materials, and make the product warranties void. Store the material in a dry place, protected from weather conditions such as rain and humidity, to prevent the formation of condensation inside the busbars.  
Also ensure that the busbars are protected from smoke, water, soil, mud, dust, or dirt in general. Position the material in a way that prevents a physical damage to it.  
It is recommended that the material is stored indoor, in a dry location. In case of storing the busbars outside for short-medium periods, ensure that it is appropriately protected, to avoid accidental infiltration of water, which will result in them being damaged.  
The material can be transported and stored at a temperature between -25°C and +55°C.  
Handling operations must be carried out implementing all the necessary precautions to ensure the integrity of the materials. The manufacturer shall not be held responsible for any material damage caused by failure to ensure appropriate protection.

Material handling

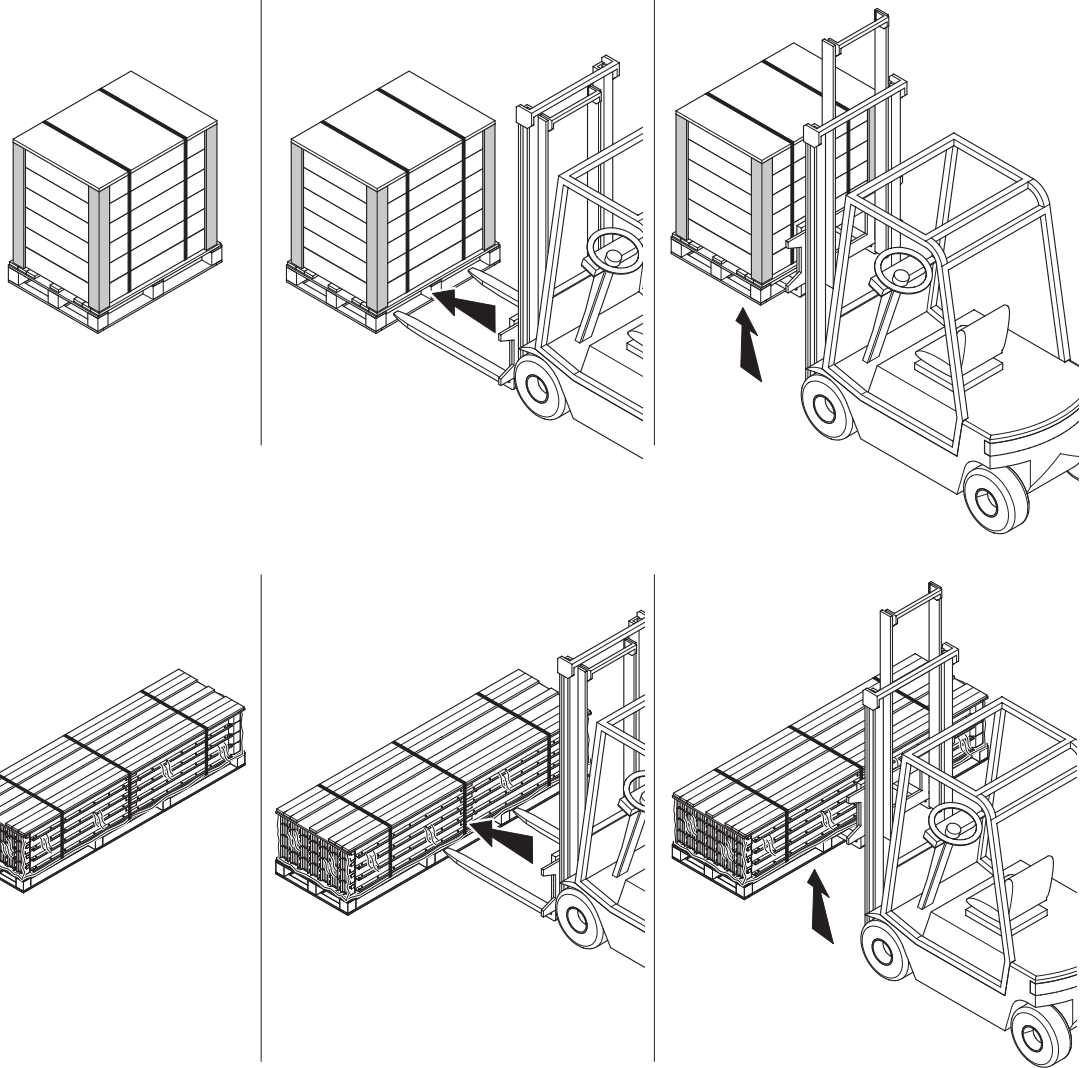

# ZUCCHINI

## 2.3 Weight table

	Rated current	In [A]	630	800	1000	1250	1600	2000	2500	3200	4000	5000
<b>XCP-HP 3C AL</b>	Weight (PE 1)	p [kg/m]	14,5	14,5	15,8	16,9	22,0	25,1	32,6	40,2	45,8	79,7
	Weight (PE 2)	p [kg/m]	17,8	17,8	19,1	20,2	27,1	31,6	41,3	50,5	57,1	96,7
	Weight (PE 3)	p [kg/m]	15,5	15,5	16,9	18,0	23,6	27,0	35,4	43,6	49,5	85,2
<b>XCP-HP 4C AL</b>	Weight (PE 1)	p [kg/m]	16,0	16,0	17,8	19,3	25,4	29,4	37,7	47,3	54,3	91,0
	Weight (PE 2)	p [kg/m]	19,3	19,3	21,1	22,6	30,5	35,9	46,4	57,6	65,7	108,0
	Weight (PE 3)	p [kg/m]	17,1	17,1	18,9	20,3	27,1	31,2	40,5	50,7	58,0	96,5
<b>XCP-HP 5C AL</b>	Weight (PE 1)	p [kg/m]	17,6	17,6	19,7	21,6	28,7	33,4	42,7	54,3	62,8	101,9
	Weight (PE 2)	p [kg/m]	20,9	20,9	23,0	24,9	33,8	39,9	51,4	64,6	74,2	118,9
	Weight (PE 3)	p [kg/m]	21,1	18,7	20,8	22,7	30,4	35,3	45,5	57,7	66,5	107,5
<b>XCP-HP 2N AL</b>	Weight (PE 1)	p [kg/m]	17,6	17,6	19,7	21,6	28,7	33,4	42,7	54,3	62,8	101,9
	Weight (PE 2)	p [kg/m]	20,9	20,9	23,0	24,9	33,8	39,9	51,4	64,6	74,2	118,9
	Weight (PE 3)	p [kg/m]	21,1	18,7	20,8	22,7	30,4	35,3	45,5	57,7	66,5	107,5

	Rated current	In [A]	630	800	1000	1250	1600	2000	2500	3200	4000	5000
<b>XCP-HP 3C Cu</b>	Weight (PE 1)	p [kg/m]	18,7	22,9	24,9	28,0	41,6	49,9	60,3	78,6	103,2	136,2
	Weight (PE 2)	p [kg/m]	22,0	26,2	28,2	32,4	45,9	56,4	69,0	88,9	114,5	151,6
	Weight (PE 3)	p [kg/m]	19,7	23,9	25,9	29,5	43,0	51,8	63,1	82,0	106,9	140,4
<b>XCP-HP 4C Cu</b>	Weight (PE 1)	p [kg/m]	21,2	26,9	29,6	33,5	50,3	62,2	74,2	97,9	130,3	173,6
	Weight (PE 2)	p [kg/m]	24,5	30,2	32,9	37,8	54,7	68,7	83,0	108,2	141,6	189,1
	Weight (PE 3)	p [kg/m]	22,3	28,0	30,7	34,9	51,8	64,1	77,1	101,3	133,9	178,7
<b>XCP-HP 5C Cu</b>	Weight (PE 1)	p [kg/m]	23,8	31,1	34,5	39,0	60,0	74,3	88,2	117,3	157,4	209,0
	Weight (PE 2)	p [kg/m]	27,2	34,5	37,8	43,4	64,3	80,8	96,9	127,6	168,8	224,4
	Weight (PE 3)	p [kg/m]	24,9	32,2	35,5	40,4	61,4	76,1	91,1	120,6	161,1	213,2
<b>XCP-HP 2N Cu</b>	Weight (PE 1)	p [kg/m]	23,8	31,1	34,5	39,0	60,0	74,3	88,2	117,3	157,4	209,0
	Weight (PE 2)	p [kg/m]	27,2	34,5	37,8	43,4	64,3	80,8	96,9	127,6	168,8	224,4
	Weight (PE 3)	p [kg/m]	24,9	32,2	35,5	40,4	61,4	76,1	91,1	120,6	161,1	213,2

## 2.4 Handling and lifting



**WARNING**

All lifting operations refer to a single component.

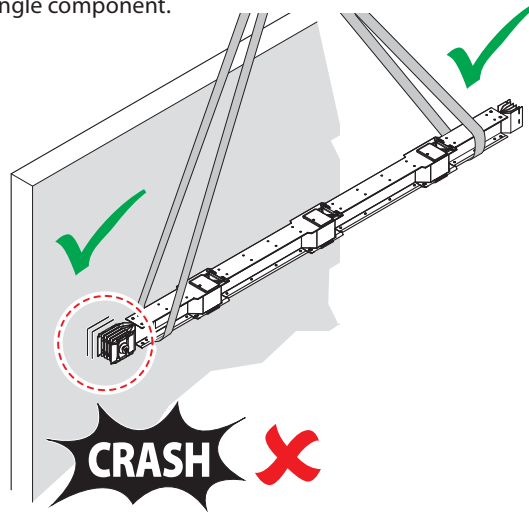

Fig. 1  
Handle the busbars with due care and attention. Do not subject busbars to torsions, dents, violent impact, or sharp movements that may damage their internal components.

Fig. 1

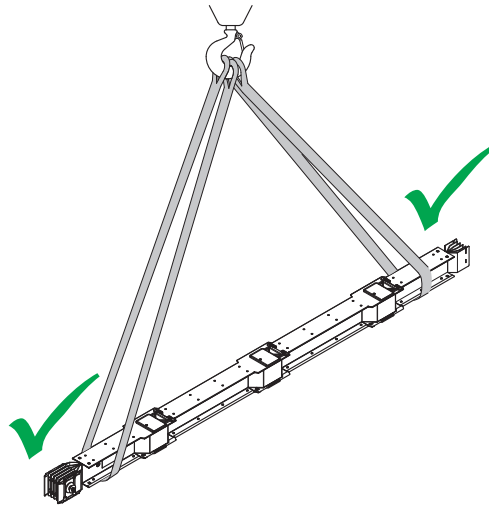

Fig. 2  
Correct way of lifting the busbars.

Fig. 2

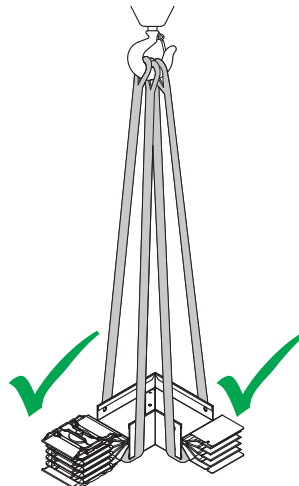
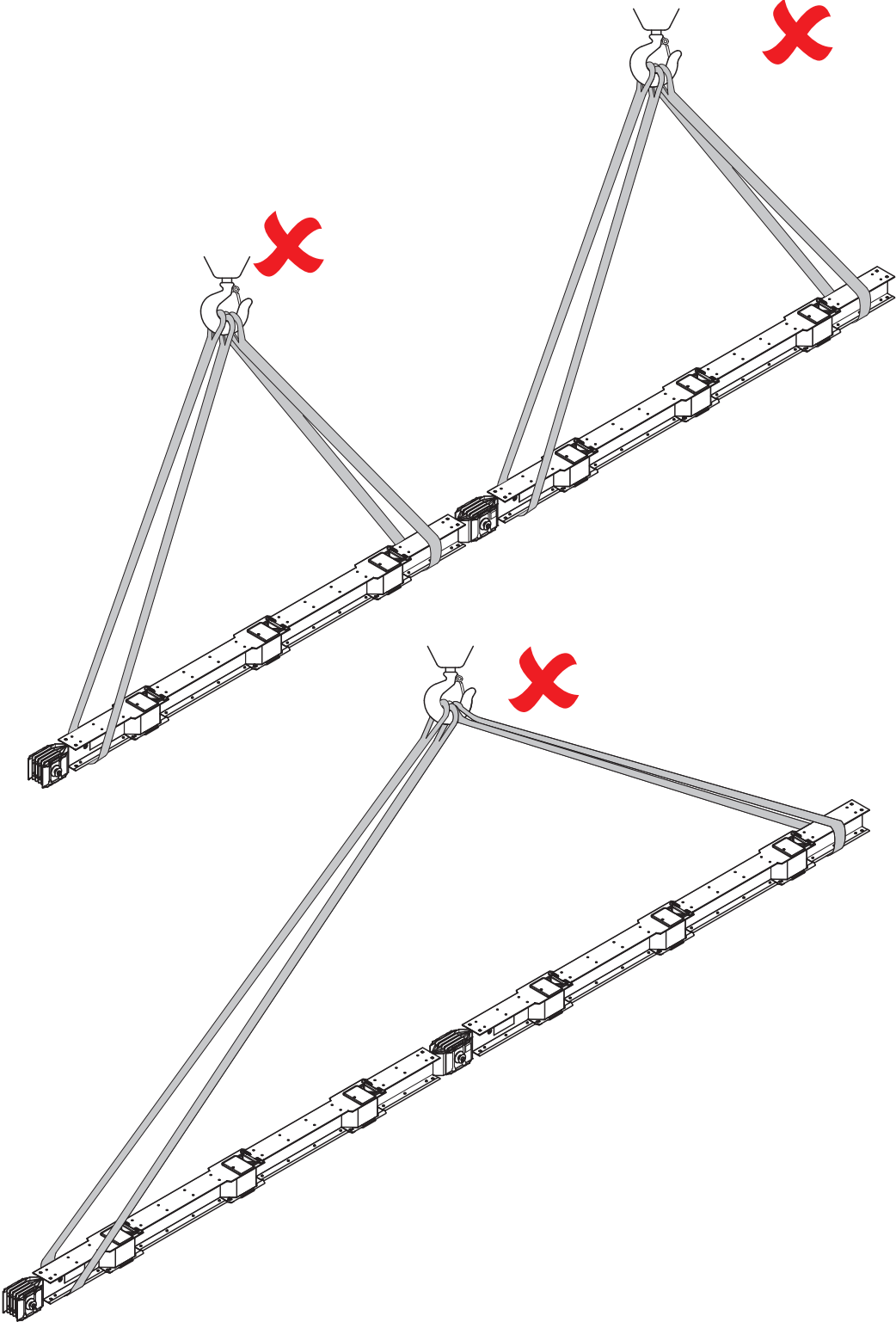

Fig. 3  
When lifting not linear shape path components, pay particular attention to their own centre of gravity. Use equipment that will not damage surfaces.

Fig. 3



# ZUCCHINI

---

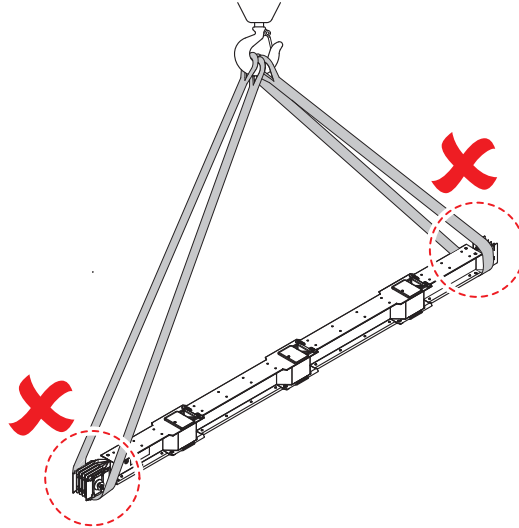

Fig. 4  
Do not lift  
the busbars from  
their ends.

Fig. 4

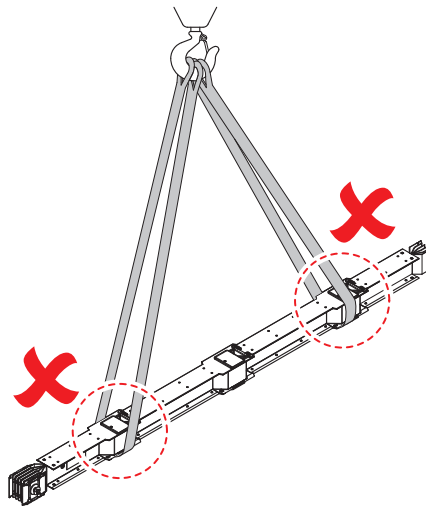

Fig. 5  
Do not use  
belts or other  
systems to lift them  
to the junction  
windows.

Fig. 5

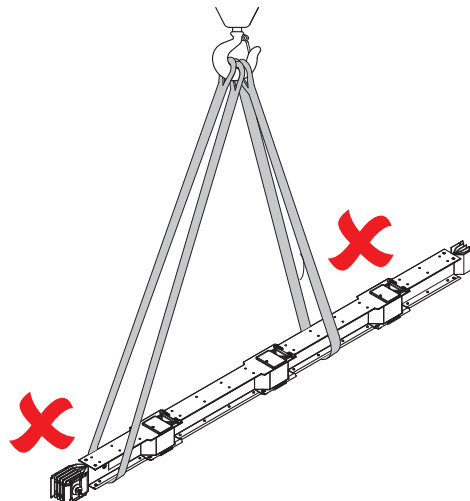

Fig. 6  
Do not use  
belts or other  
systems to lift  
the busbars in  
unbalanced  
positions.

Fig. 6



## **2.5 Missing or damaged components**

### **GOOD RECEPTION**

Upon receipt of the goods check the following:

- 1) integrity of the packaging, and the goods, if delivered in a see-through package.
- 2) consistency of the material with the delivery note and the packing list, if supplied.
- 3) consistency of the material with the order acknowledgement details.

In case of any disclaims, please inform us in writing following the instructions found in the notifications section.

### **NOTIFICATIONS**

In case of any disclaim, please forward your official complaint to a Legrand referent.

When notifying that a wrong item has been received, please indicate the item code no. found on the packaging, and the item code no. found on the part (if possible include a photo of the labels).

## 2.6 Product type identification

Before beginning installation, you must compare the plan which you received from the design office project al layout of the building. For custom-made products based on specific projects, check the system drawing to ensure that the components match.

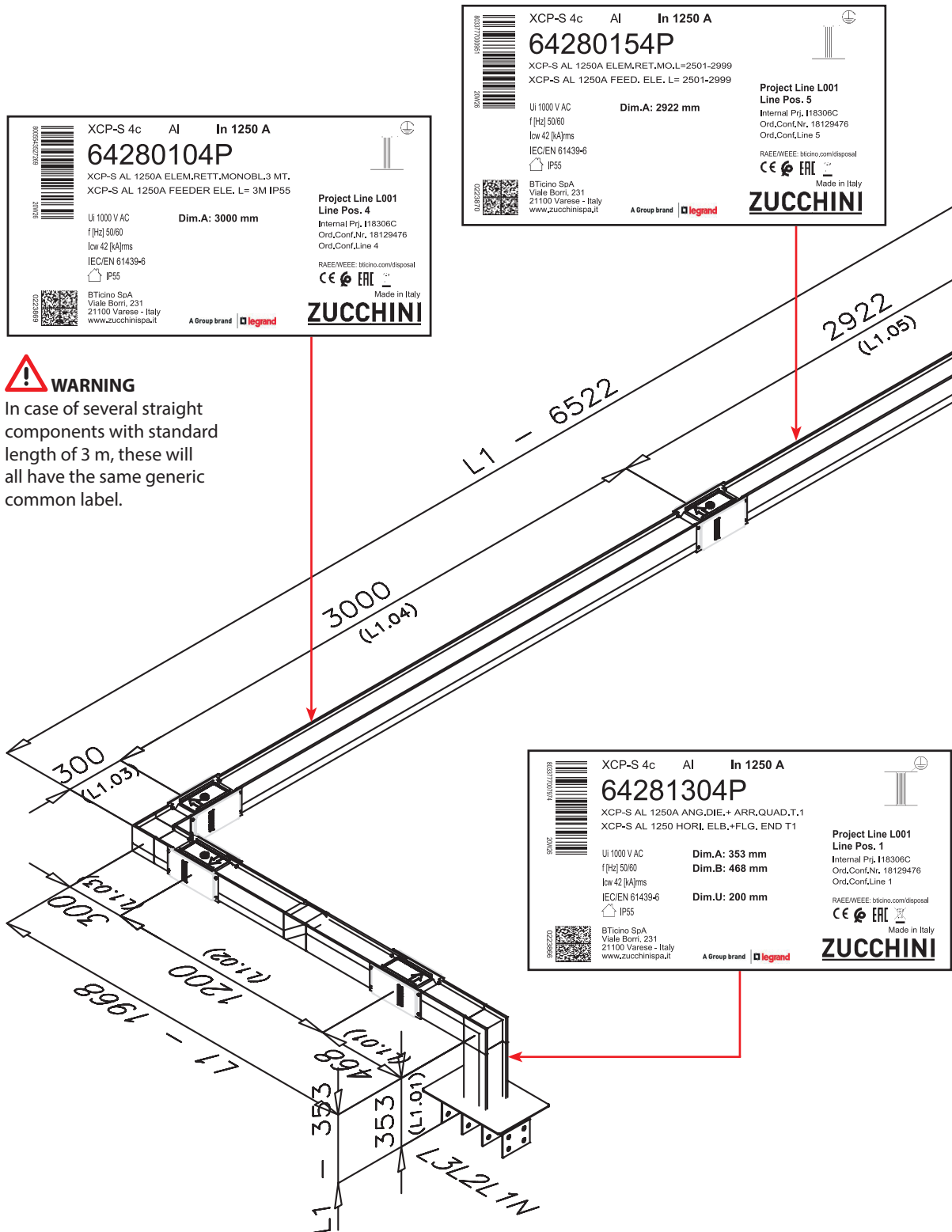

**XCP-S 4c AI In 1250 A**  
**64280404P**  
 XCP-S AL 1250A ANGOLO PIANO MON. DX ST  
 XCP-S AL 1250A VERTICAL ELBOW RH STD

Project Line L001  
 Line Pos. 6  
 Internal Prj. I18306C  
 Ord.Conf.Nr. 18129476  
 Ord.Conf.Line 6

Ui 1000 V AC  
 f [Hz] 50/60  
 Icw 42 [kA]rms  
 IEC/EN 61439-6  
 IP55

Dim.A: 300 mm  
 Dim.B: 300 mm

RAEE/WEEE: bticino.com/disposal  
 CE ENEC  
 Made in Italy  
**ZUCCHINI**

B.Ticino SpA  
 Viale Borri, 231  
 21100 Varese - Italy  
 www.zucchinispa.it

A Group brand | **legrand**

Code	Descrizione Estesa EN
ZU-64281304P	XCP-S AL 1250A HORI. ELB.+FLG. END T1
ZU-64287124P	XCP-S AL 1250A STR.LENG INVER.FASI L.1,2MT
ZU-64280404P	XCP-S AL 1250A VERTICAL ELB. RH STD
ZU-64280104P	XCP-S AL 1250A FEEDER ELE. L=3M
ZU-64280154P	XCP-S AL 1250A FEEDER ELE. L=2501-2999
ZU-64280404P	XCP-S AL 1250A VERTICAL ELB. RH STD
ZU-64281334P	XCP-S AL 1250A HORI. ELB.+FLG. END T4

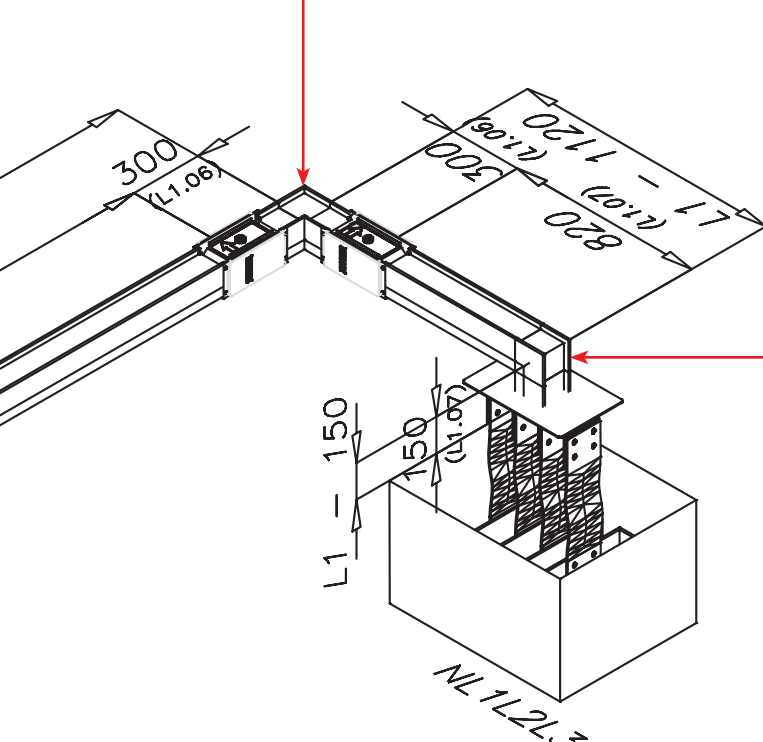

**XCP-S 4c AI In 1250 A**  
**64281334P**  
 XCP-S AL 1250A ANG.DIE.+ UB.MON.T.4  
 XCP-S AL 1250 HORI. ELB.+FLG. END T4

Project Line L001  
 Line Pos. 7  
 Internal Prj. I18306C  
 Ord.Conf.Nr. 18129476  
 Ord.Conf.Line 7

Ui 1000 V AC  
 f [Hz] 50/60  
 Icw 42 [kA]rms  
 IEC/EN 61439-6  
 IP55

Dim.A: 150 mm  
 Dim.B: 820 mm  
 Dim.U: 200 mm

RAEE/WEEE: bticino.com/disposal  
 CE ENEC  
 Made in Italy  
**ZUCCHINI**

B.Ticino SpA  
 Viale Borri, 231  
 21100 Varese - Italy  
 www.zucchinispa.it

A Group brand | **legrand**

Details of the adhesive label found on each component.

**XCP-S 4c AI In 1250 A**  
**64280154P**  
 XCP-S AL 1250A ELEM.RET.MO.L=2501-2999  
 XCP-S AL 1250A FEED. ELE. L= 2501-2999

Project Line L001  
 Line Pos. 5  
 Internal Prj. I18306C  
 Ord.Conf.Nr. 18129476  
 Ord.Conf.Line 5

Ui 1000 V AC  
 f [Hz] 50/60  
 Icw 42 [kA]rms  
 IEC/EN 61439-6  
 IP55

Dim.A: 2922 mm

RAEE/WEEE: bticino.com/disposal  
 CE ENEC  
 Made in Italy  
**ZUCCHINI**

B.Ticino SpA  
 Viale Borri, 231  
 21100 Varese - Italy  
 www.zucchinispa.it

A Group brand | **legrand**

Bar code EAN12  
 Year and week of production  
 Insulation voltage  
 Frequency  
 Short circuit current  
 Standard reference  
 Degree of protection

Type of busduct  
 Conductors material  
 Rated Current  
 Item Code  
 Item Description

Configuration  
 Reference line (\*)  
 Item position (\*)  
 Internal project Name (\*\*)  
 Order confirmation number (\*\*)  
 Position in the order confirmation (\*\*)

Data matrix with Serial number of piece  
 Address  
 Element dimensions (\*)  
 Marking  
 Brand

(\*) Optional field  
 (\*\*) Fields to be provided to customer care in case of problem



QR code containing all the identification datas of the specific piece with relative quality check details.

## 3. Installation



### WARNING

Where not differently specified, dimensions indicated in the manual are to be intended in millimeters (mm).

### 3.1 Checks before installation

#### 3.1.1 Visual / electric checks

Before the installation, all material should be inspected for damage.  
When installing the busbars comply with the following:

- 1 Do not position the busbars near pipes containing liquids.
- 2 For the installation only use bracketing systems supplied by Legrand, and follow the instructions found in the catalogue or enclosed with the item.
- 3 Only use accessories supplied by Legrand.
- 4 Check that the operating voltage coincides with that indicated on the product plate.
- 5 Check that the system operating current does not exceed the product rated current, downgrade it if required.
- 6 Check if the busbar capacity must be derated (for example due to high ambient temperature, presence of harmonics, etc.)
- 7 Do not install the standard product in particular environments (high concentration of chlorine, explosive atmosphere, etc.).
- 8 For outdoor installations, protect the busbar with a protection canopy. The IP55 protection degree can be affected by unsuitably protected outdoor installation.

#### 3.1.2 General rules for installing supports

##### Hazard of improper installation

**Before installation:** be sure to have well the layout plan

**During installation:** be sure to consider correct separation distances between the supports. These have to be levelled, so to guarantee final levelling also for path components.

Be sure that all supports are able to sustain the weights of the path components.

**Failure to follow these instructions can result in injury or equipment damage.**

##### Introduction

Correct installation of supports is fundamental to realize a proper installation of path components.

Here below, a list of rules to take into account during installation of supports and path components.

##### General Installation rules for supports

Follow these general rules for installing supports:

- All path components have to be correctly sustained
- To get advantage in installation, be sure to use more than one support for each path component
- The supporting capacity of the support must be at least the weight of the path component plus 90 kg, in accordance with IEC 61439-6.
- Use different support for components at the terminal ends of the path.
- Be sure to not sustain weight of end components by transformers or switchboards.

Edgewise horizontal installation:

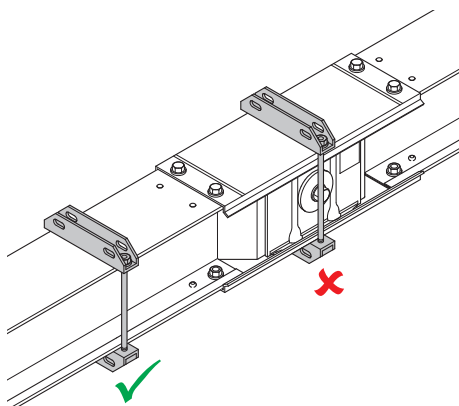

Flatwise horizontal installation:

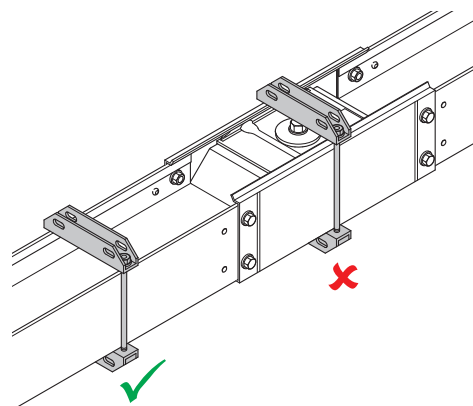

- Sustain vertical branches near to the elbow angle.
- Make sure that a mounting bracket is installed on each branch of the double elbow.
- Even if supports have to be installed near to joint blocks, it has never to be put exactly under a joint block.
- In case TOBs need to be installed on the element, check the clearance before positioning the bracket.

### 3.1.3 Fixing accessories

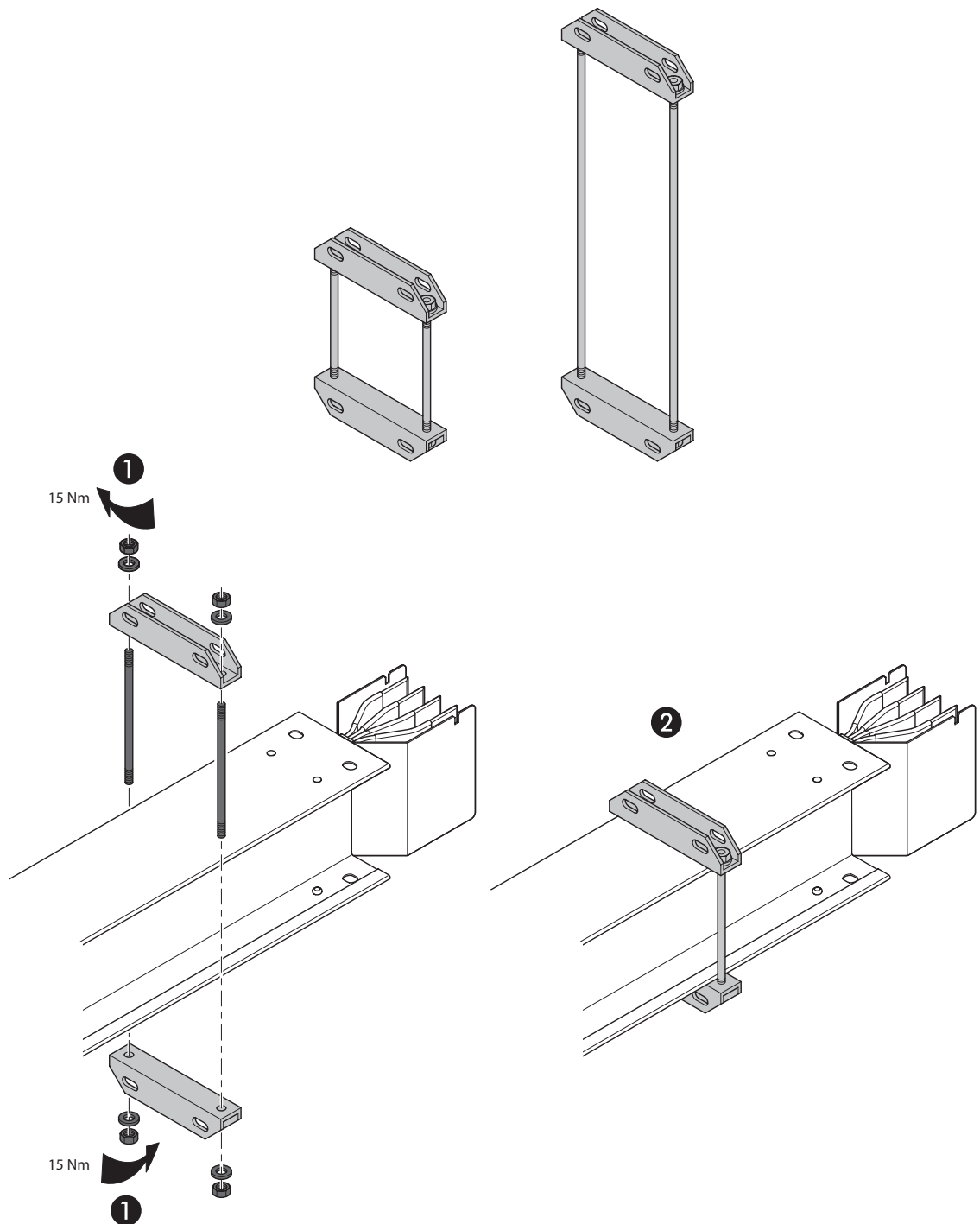

# ZUCCHINI

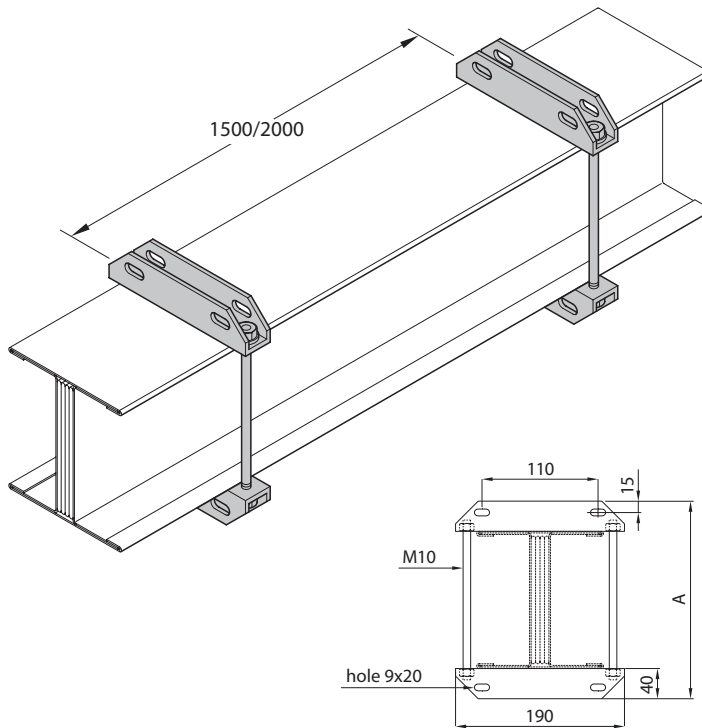

Rating XCP-S	A (mm)	
	Al	Cu
<b>630</b>	210	-
<b>800</b>	210	210
<b>1.000</b>	210	210
<b>1.250</b>	250	210
<b>1.600</b>	280	250
<b>2.000</b>	300	280
<b>2.500</b>	460	380
<b>3.200</b>	520	460
<b>4.000</b>	560	520
<b>5.000</b>	670	560
<b>6.300</b>	-	670

Rating XCP-HP	A (mm)	
	Al	Cu
<b>630</b>	210	-
<b>800</b>	210	210
<b>1.000</b>	210	210
<b>1.250</b>	210	210
<b>1.600</b>	280	250
<b>2.000</b>	300	250
<b>2.500</b>	460	300
<b>3.200</b>	520	460
<b>4.000</b>	560	520
<b>5.000</b>	820	560
<b>6.300</b>	-	760

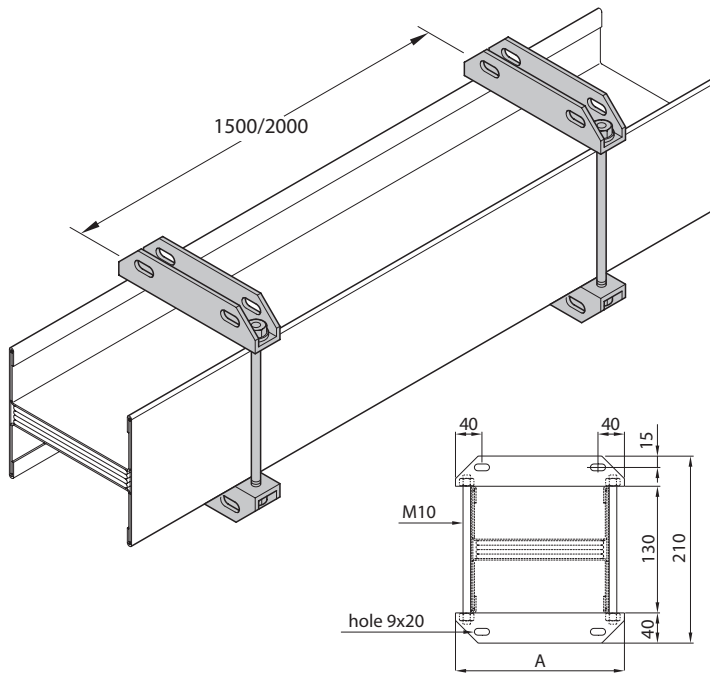

Rating XCP-S	A (mm)	
	Al	Cu
<b>630</b>	190	-
<b>800</b>	190	190
<b>1.000</b>	190	190
<b>1.250</b>	315	190
<b>1.600</b>	315	315
<b>2.000</b>	315	315
<b>2.500</b>	430	430
<b>3.200</b>	490	430
<b>4.000</b>	530	490
<b>5.000</b>	640	530
<b>6.300</b>	-	640

Rating XCP-HP	A (mm)	
	Al	Cu
<b>630</b>	190	-
<b>800</b>	190	190
<b>1.000</b>	190	190
<b>1.250</b>	190	190
<b>1.600</b>	315	315
<b>2.000</b>	315	315
<b>2.500</b>	430	315
<b>3.200</b>	490	430
<b>4.000</b>	530	490
<b>5.000</b>	850	530
<b>6.300</b>	-	850

# ZUCCHINI

---

## Supports for Edgewise Installation

For edgewise installations, the maximum recommended distance between supports is 2000 mm.

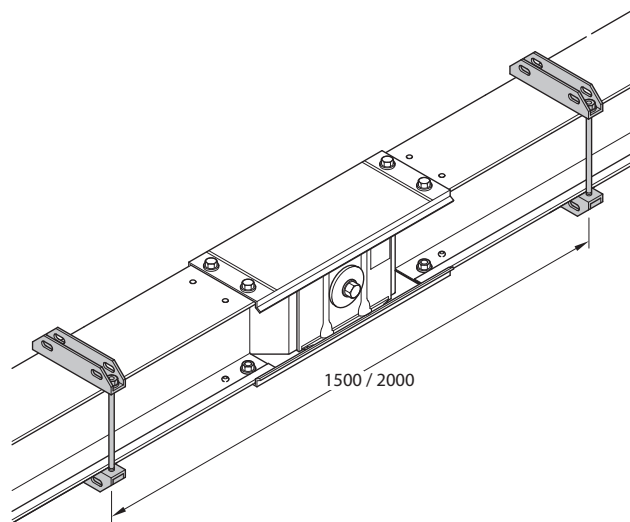

## Supports Flatwise Installation

For flatwise installations, the maximum recommended distance between supports is 2000 mm. In addition, a support must be placed at a minimum distance of 150mm from the end (joint excluded).

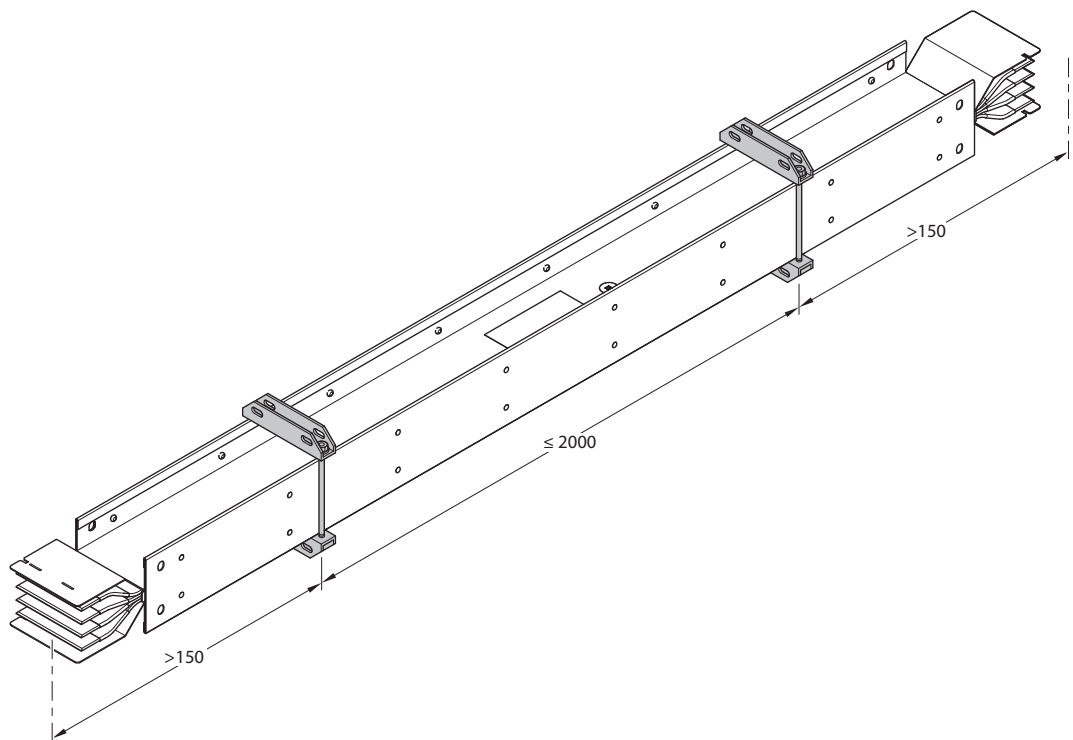



Consult always the general installation rules, before installing any type of support (see page 26)

## Horizontal Supports

The function of horizontal supports is to correctly install path components horizontally and also adjust them along the length.

Supports also have the function to absorb path components movements.

## Types of Horizontal Supports

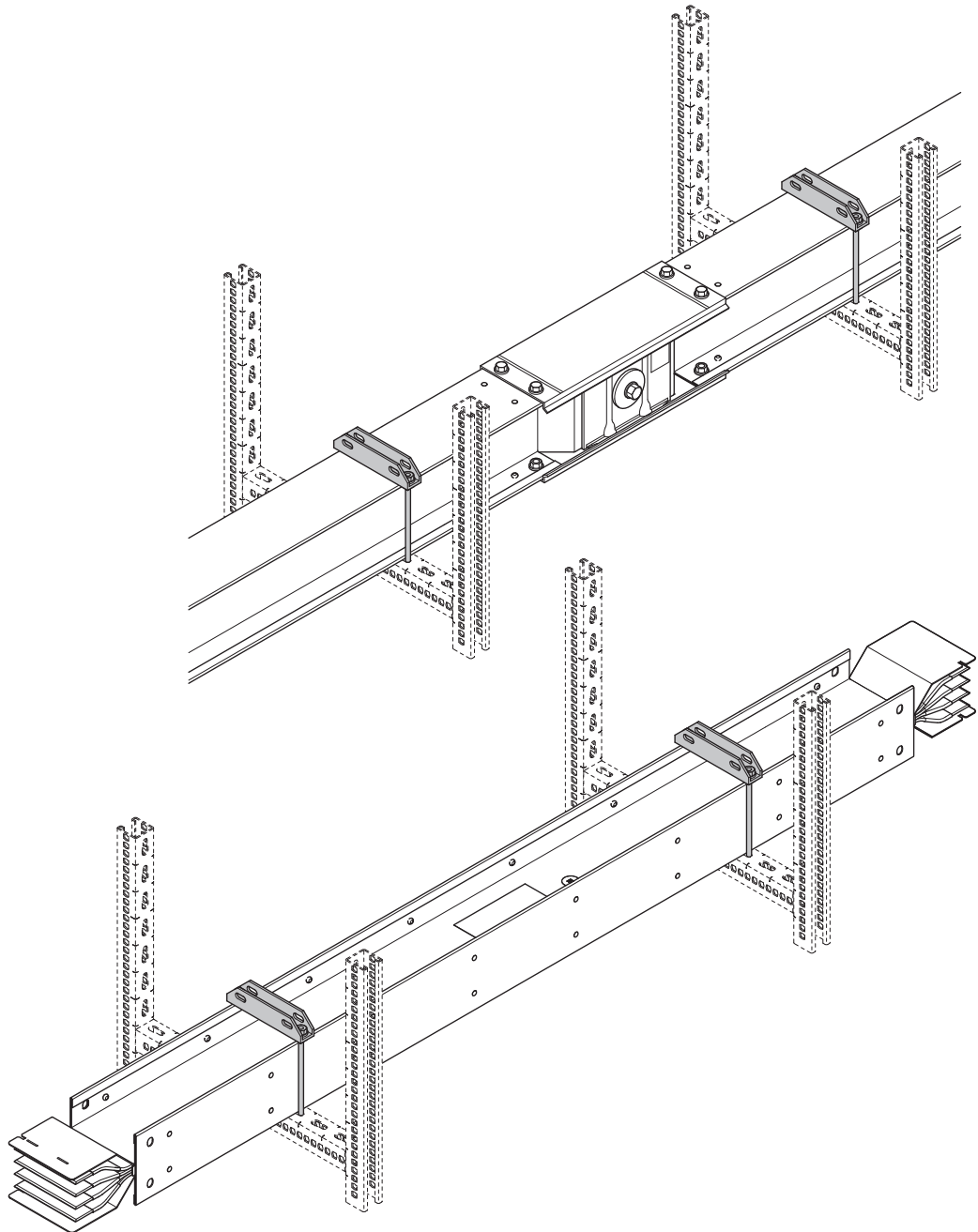

- Attached to the ceiling using 2x2 m threaded M10 rods (NOT provided within the busbar).
- Provide support for edgewise path components from the bottom.
- Attached to the ceiling.
- Provide support for flatwise path components from the bottom.
- Supports are NOT provided within the busbar.

# ZUCCHINI

---

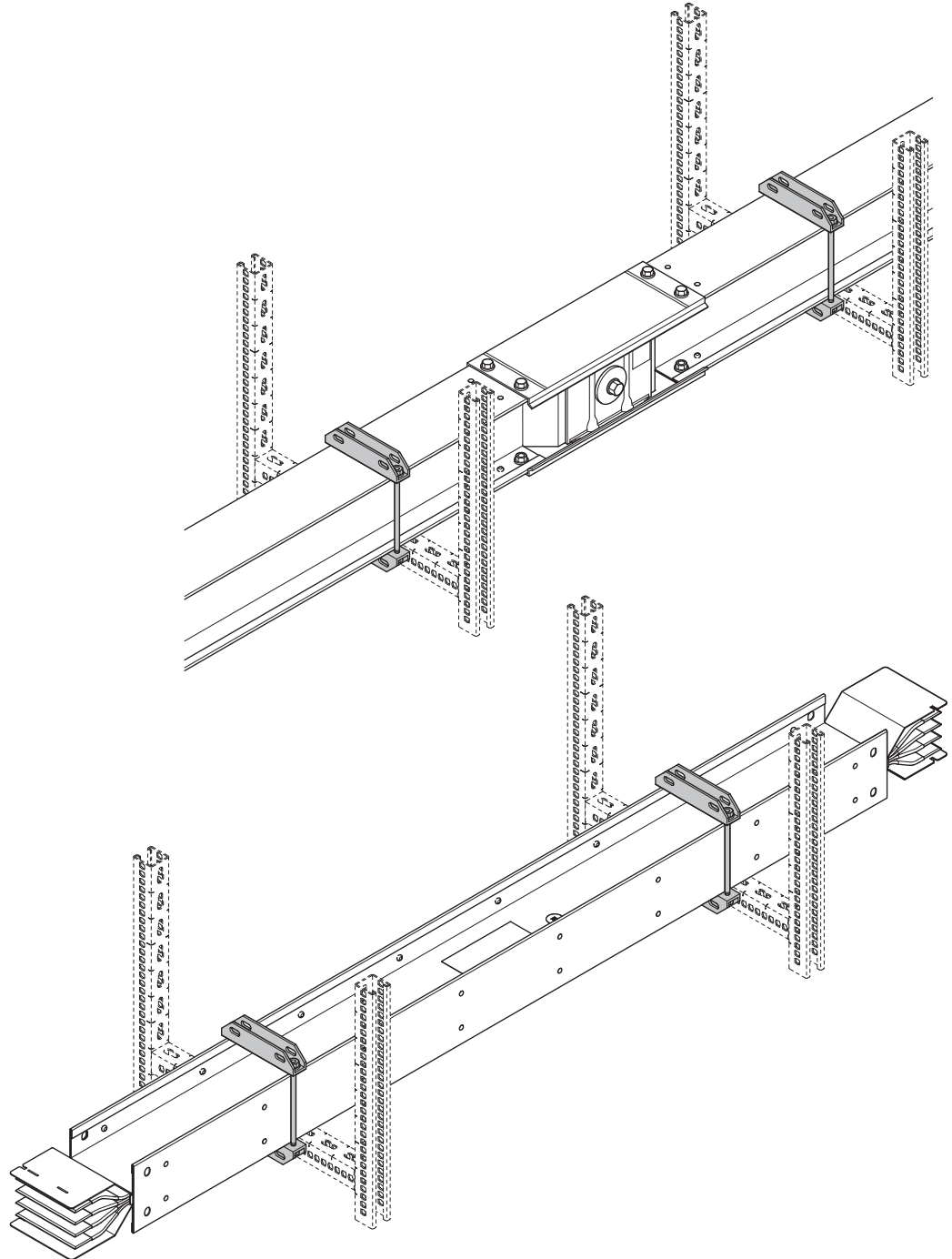

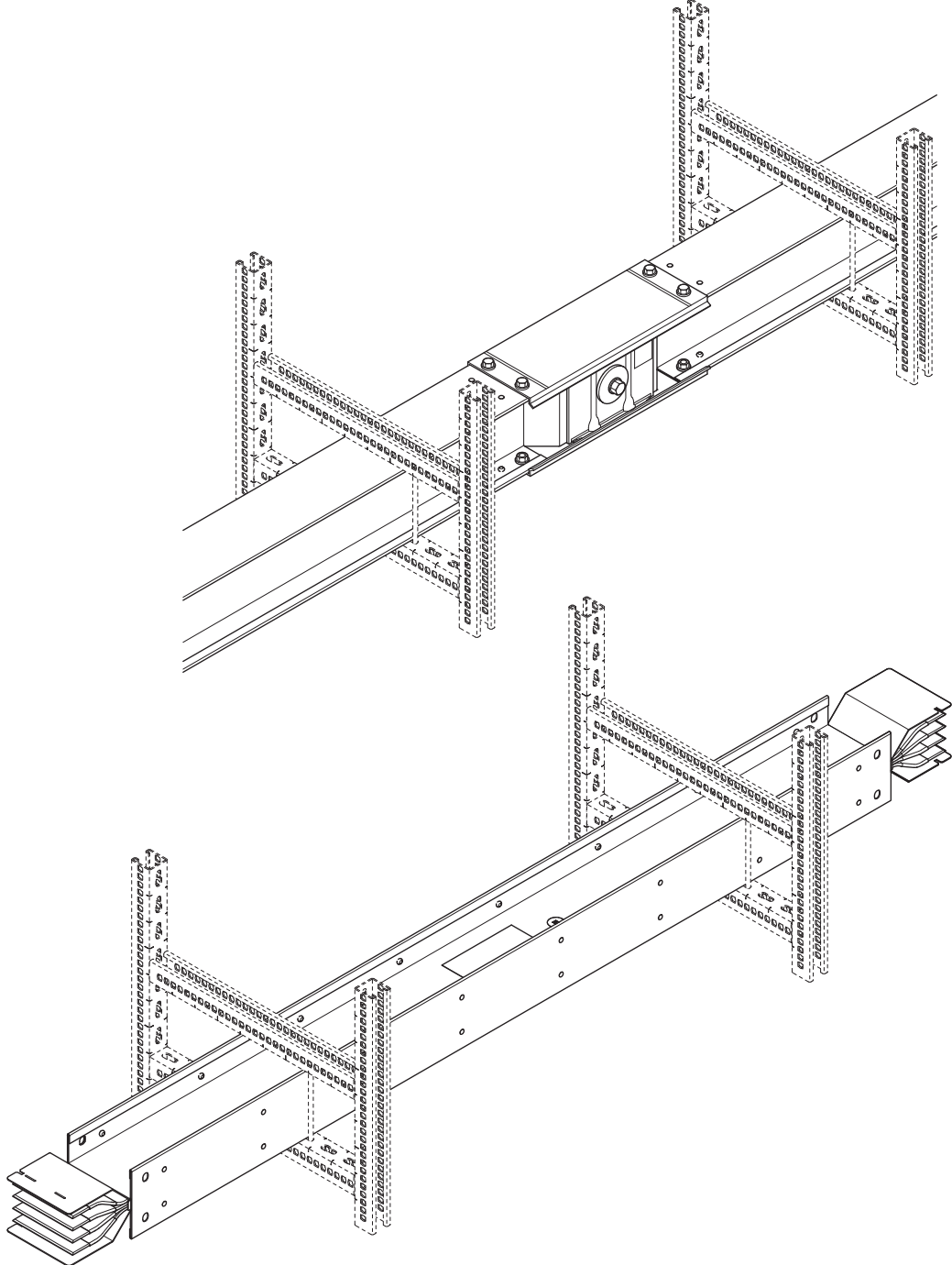

# ZUCCHINI

---

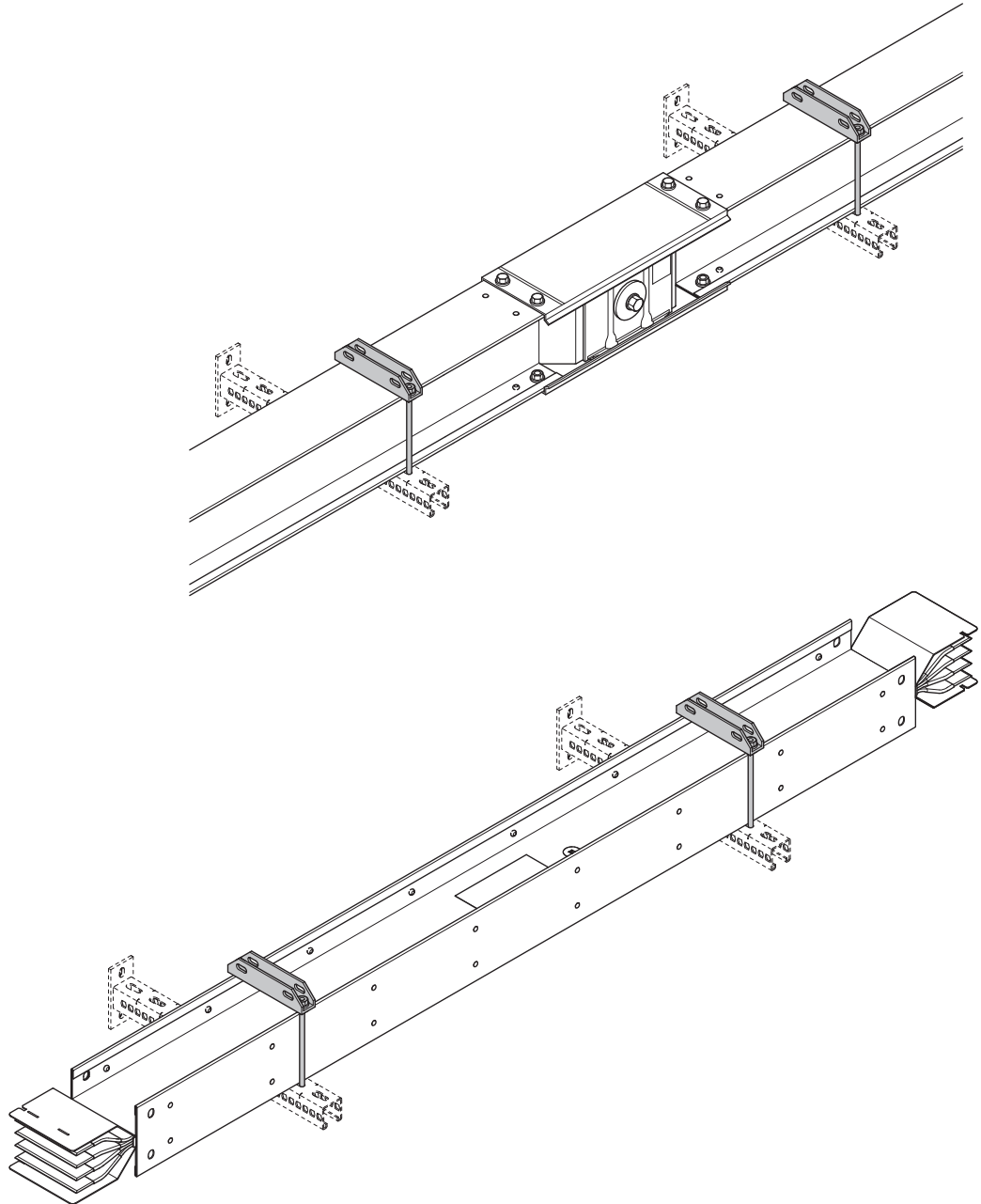

- Attached to the wall.
- Provide support for edgewise path components from the bottom.
- Supports are NOT provided within the busbar.
- Attached to the wall.
- Provide support for flatwise path components from the bottom.
- Supports are NOT provided within the busbar.
- Fixe the bar on the wall support.

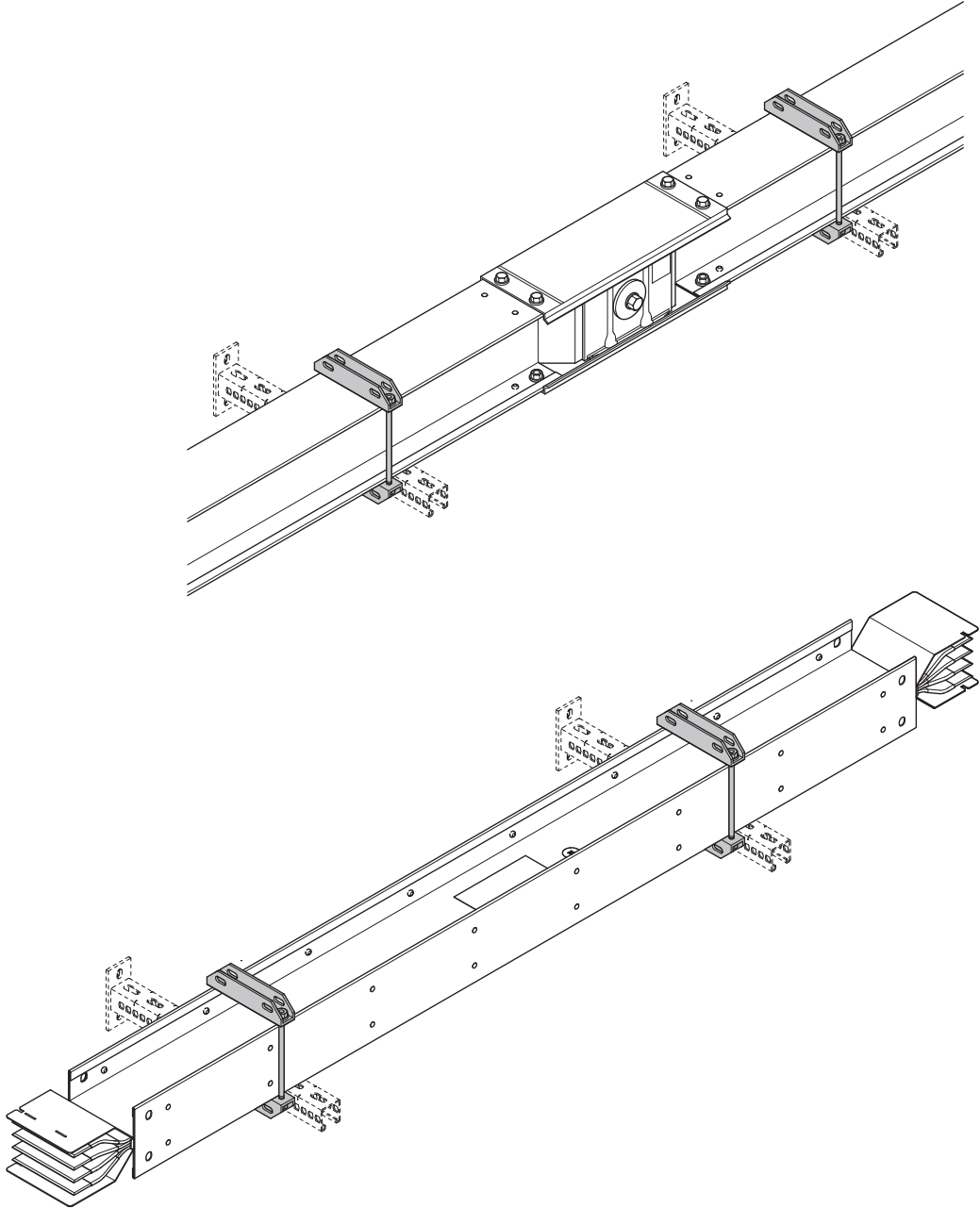

# ZUCCHINI

---

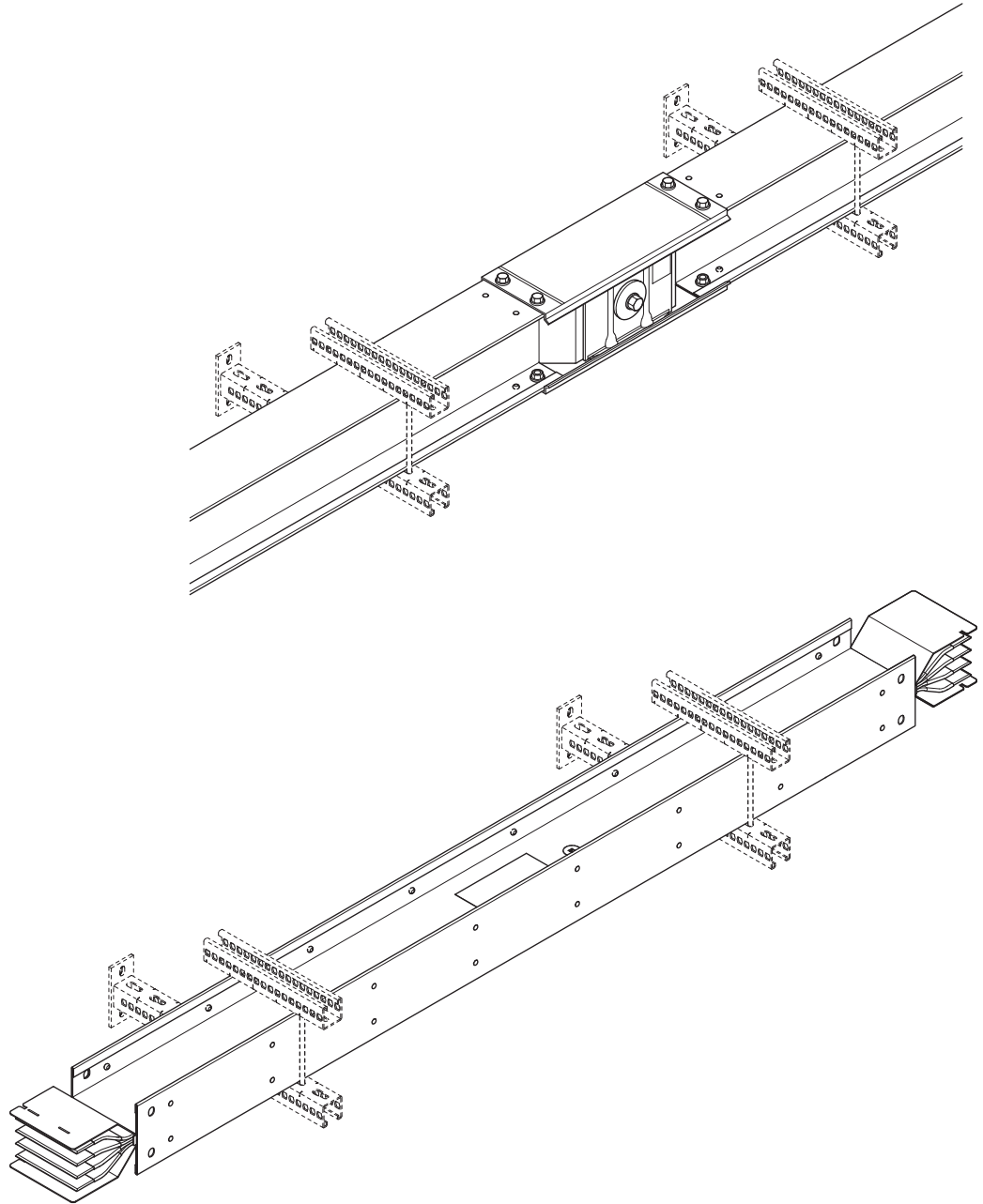

 **WARNING**

**All the dihedral angle components must be supported at the point of the change of direction.  
All drawings refer to standard dimensions; for special sizes, in case of doubt, check the bracket points with Legrand.**

Use dedicated supports for components at the terminal ends of the path.  
Be aware to have enough space to connect cables by customer.

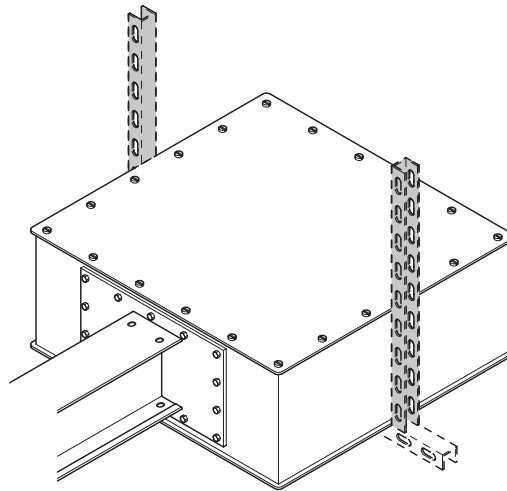

**Supports for flatwise elbows components**

Elbows components must have a support installed across the elbow angle.

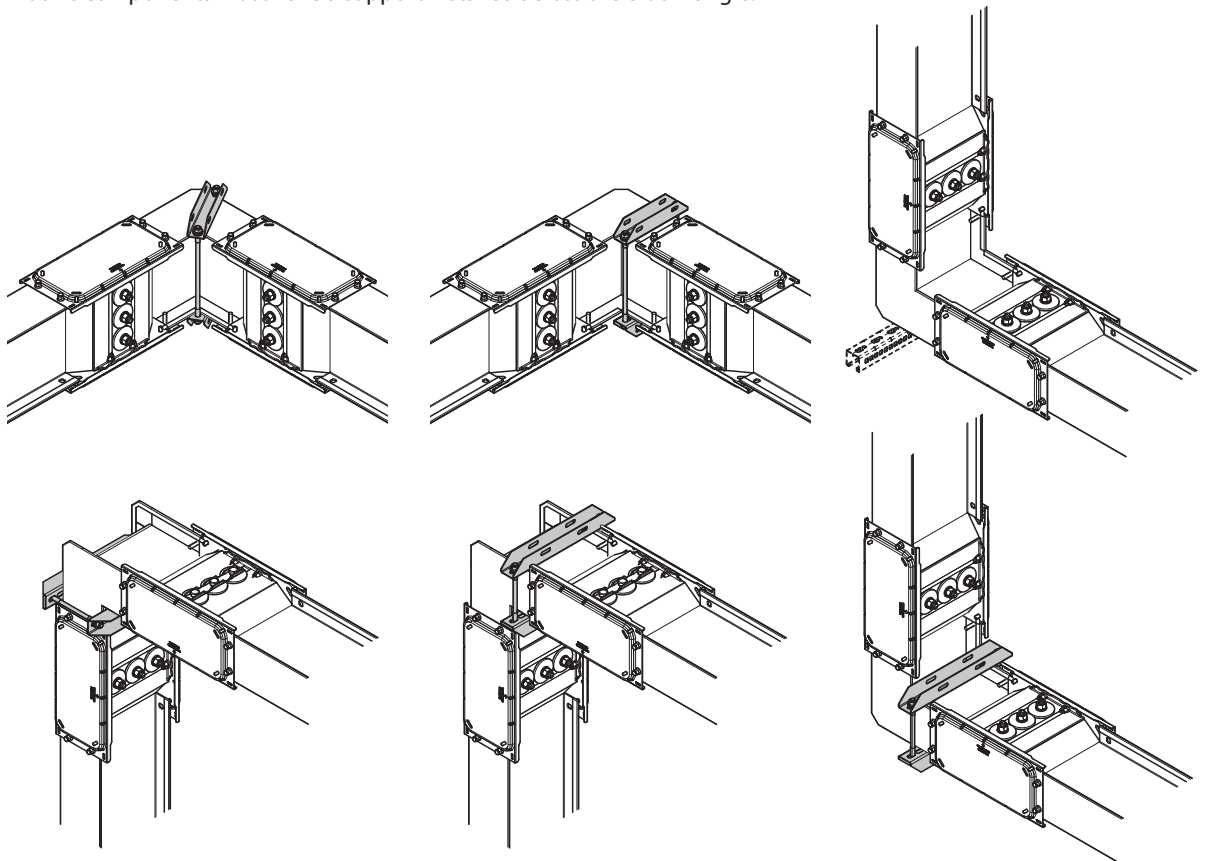

# ZUCCHINI

---

## Supports for T components

T components must have a support installed across the T-joint.  
Diagonal supports are not supplied.

TEEO

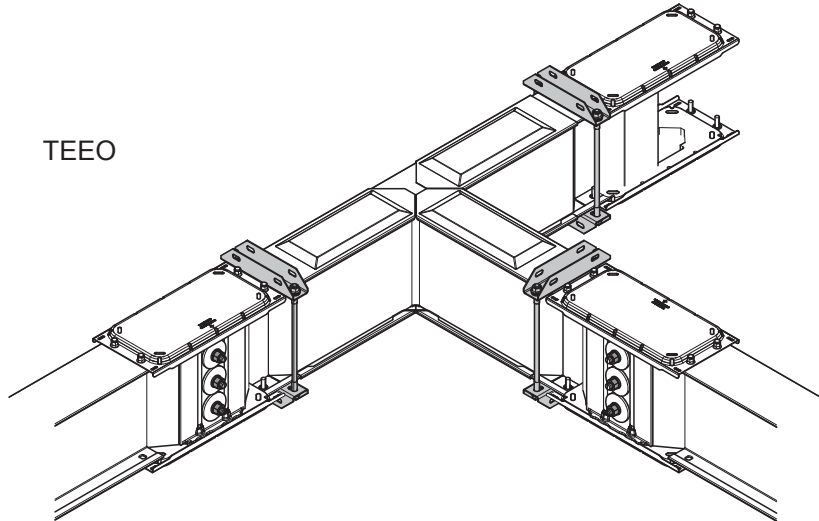

TEEV

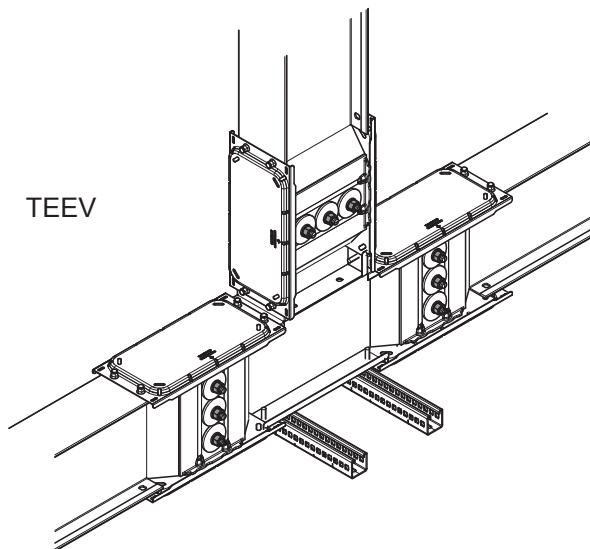



## 3.2 Installation of wall supports

### 3.2.1 Installation sizes, distances and positioning logics

Below are some precautions that may be useful to avoid problems during the assembly, which we recommend should be taken into account during the design.

#### Minimum distances from the structure

The minimum distance from the walls, to avoid problems during edgewise installation of the busbar, is 300 mm. The variables that must be taken into account for correct assembly are:

- position of the bolt for tightening the Monobloc; the minimum required distance is 100 mm;
- sizes of the distribution element (box) selected for the collection of power (at least 300 mm);
- any brackets and their assembly;
- accessibility to the screws for the installation of the brackets and the closing of the junctions;
- any material required for the actual installation in order to compensate for wall imperfections.

In case of rising mains installation, if the system does not require fire barriers, the bracket supporting can be directly secured to the wall. Otherwise, allow for a spacing support between the bracket and the wall, to ensure that the back of the busbar remains at a distance of 100 mm from the wall, therefore ensuring enough space for the positioning of the fire barriers.

#### Minimum distance of the wall / ceiling elements

Minimum installation distance when there are several adjacent lines

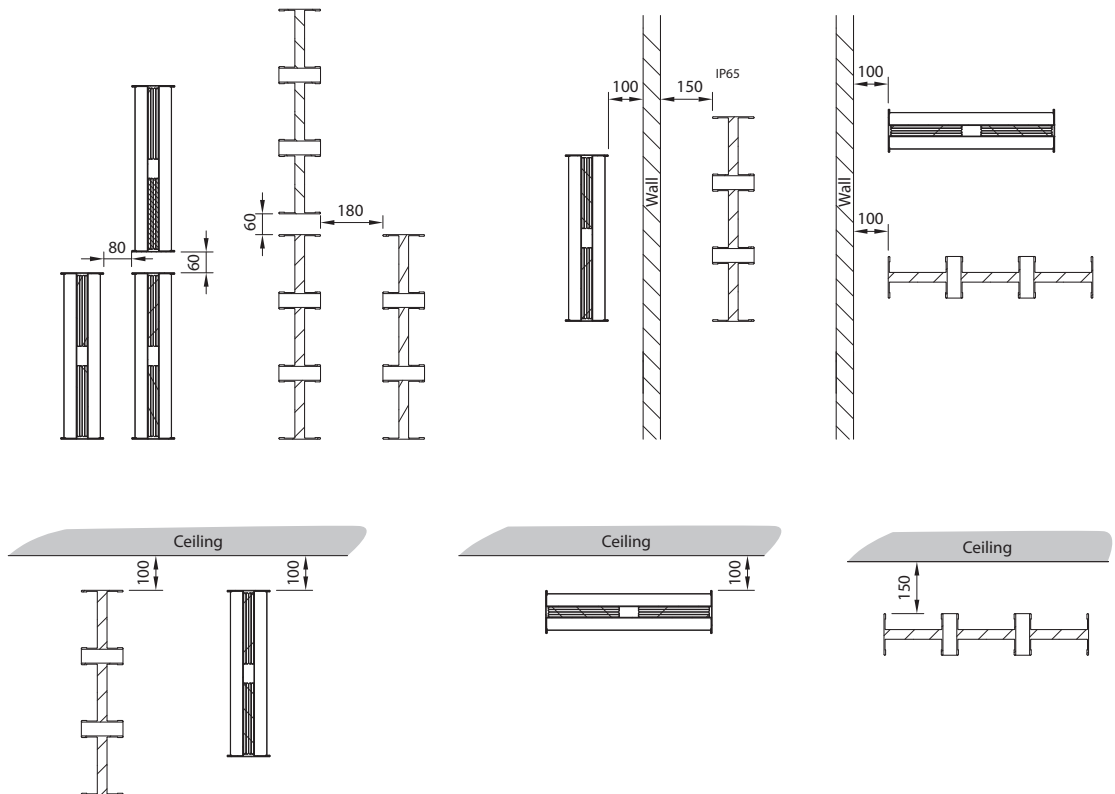

When there are tap-off units along the busbars, the minimum distances depend on the dimensions of the tap-offs selected.

\* When there is a tap-off box installed above the busbar, check the overall dimension of the open cover of the tap-off unit used in the specific section.

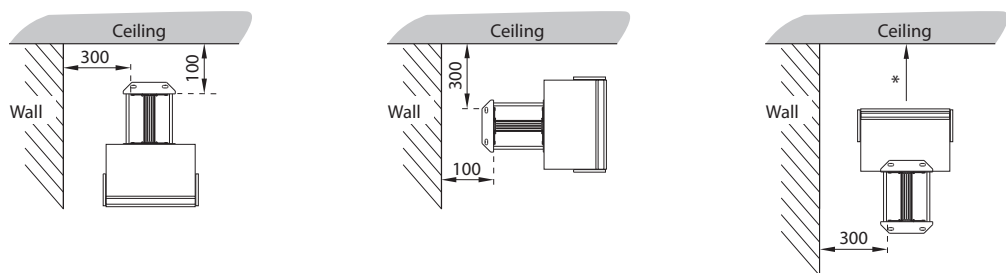

# ZUCCHINI

---

## Fixing for installation in seismic environments in horizontal

*Edgewise element.*

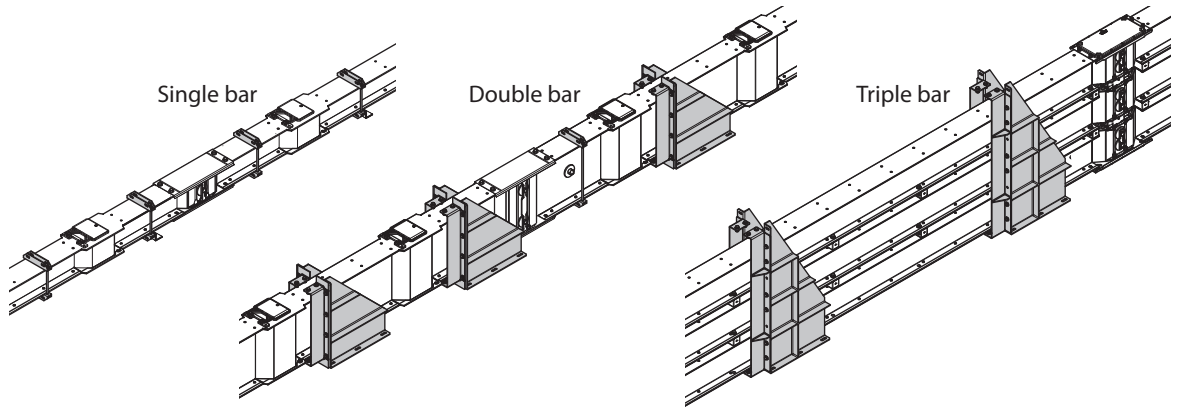

## Fixing for installation in seismic environments in vertical

Single bar / double bar

Triple bar

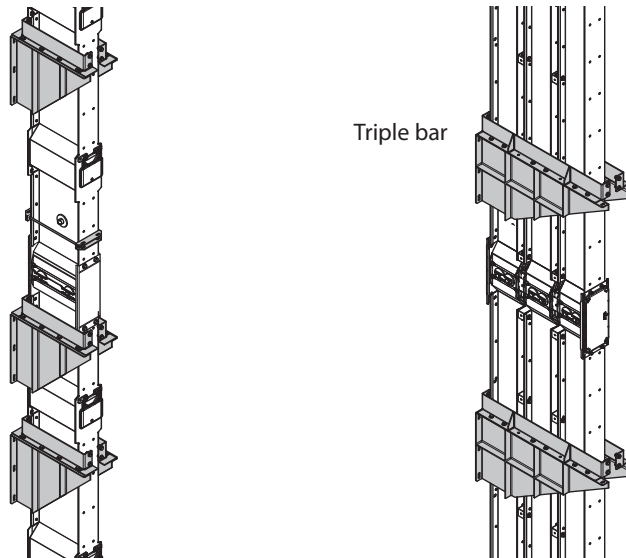

## Fixing for naval installation

For naval installations always use a type E bracket.

*Edgewise element.*

Single bar

Double bar

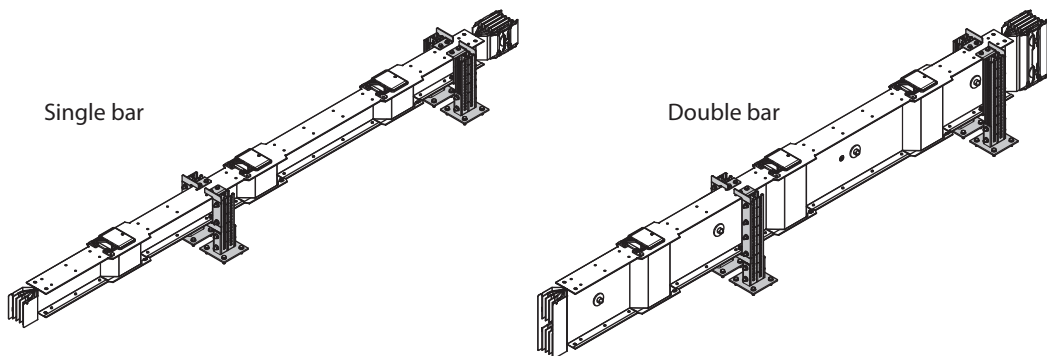

### 3.3 Detailed instructions for vertical installation

Example of vertical installation: the standard bracket can be moved if TOBs are present to avoid interference with the TOB POSITION.

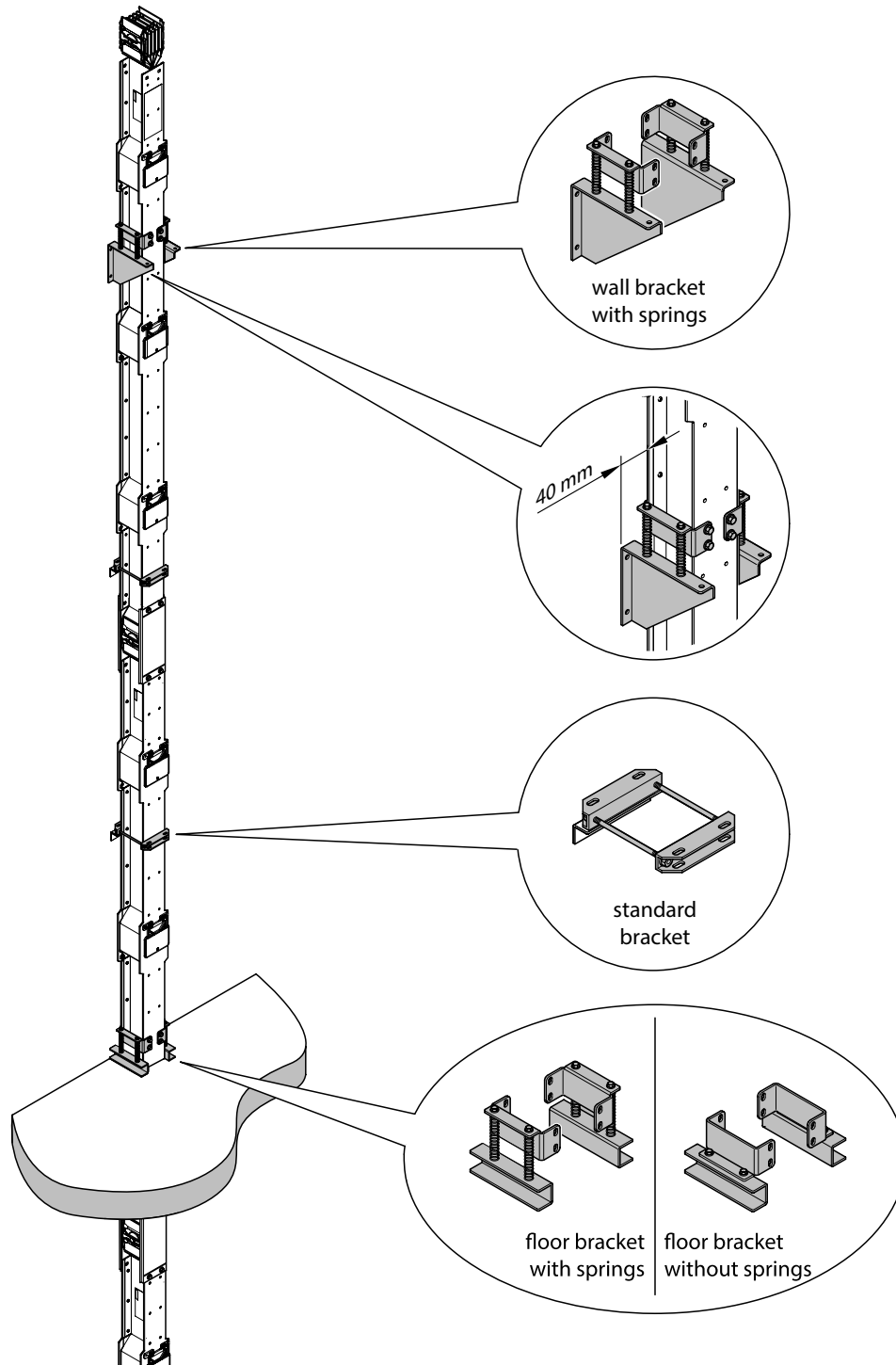

When installing a vertical busbar, strictly follow the instructions below:

- 3.3.1 Definition of spring charging
- 3.3.2 Wall and floor drilling
- 3.3.3 Attaching the brackets to the busbars
- 3.3.4 Busbar mounting in line

### 3.3.1 Charging definition in brackets with springs

Depending on the rating of the busbar, the quantity and the type of brackets being installed, check that the selected distance (D) is the same or less than the maximum distance (Dmax) between two subsequent brackets with springs.

XCP-S 4C Al		
In (A)	D max [m]	Kit Springs
630	11	4
800	10	4
1000	10	4
1250	9	4
1600	10	6
2000	9	6
2500	12	8
3200	11	12
4000	10	12
5000	8	12

XCP-S 4C Cu		
In (A)	D max [m]	Kit Springs
800	9	4
1000	8	4
1250	7	4
1600	6	4
2000	6	6
2500	9	8
3200	7	8
4000	7	12
5000	5	12
6300	4	12

For 5C version multiply Dmax by 0.9  
For 3C version multiply Dmax by 1.1

XCP-HP 4C Al		
In (A)	D max	Kit Springs
630	10	4
800	10	4
1000	10	4
1250	9	4
1600	7	4
2000	9	6
2500	11	8
3200	11	12
4000	10	12
5000	8	12

XCP-HP 4C Cu		
In (A)	D max	Kit Springs
800	9	4
1000	7	4
1250	7	4
1600	6	4
2000	6	6
2500	5	6
3200	6	8
4000	6	12
5000	5	12
6300	4	12

For 5C version multiply Dmax by 0.85  
For 3C version multiply Dmax by 1.1

If  $D \leq D_{max}$ , calculate the spring **H CHARGING** value:

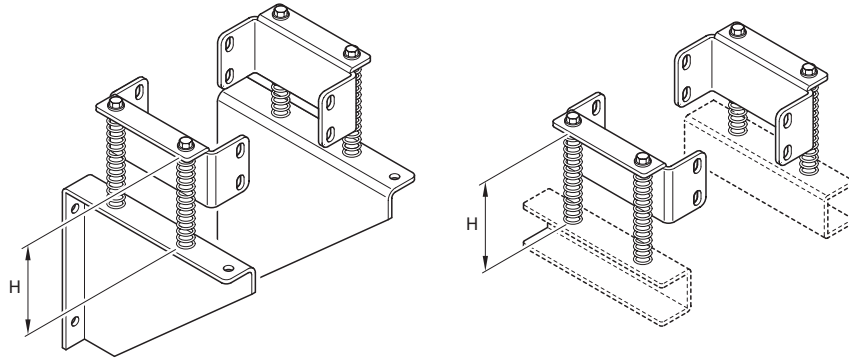

$$H = 130 - \frac{(W_b \cdot D + W_{acc})}{(3 \cdot n)}$$

Where:

- **W<sub>b</sub>**: busbar linear weight [kg/m]
- **D**: actual distance between two brackets with springs [m]
- **W<sub>acc</sub>**: sum of the weights of all the accessories connected between two brackets with springs (boxes, cables, etc.) [kg]
- **n**: total number of springs in the brackets (see previous table)
- **H**: charging [mm]. CAUTION: H should be between 105 and 130 mm

Calculation example:

TYPE OF BUSBAR: S-4C-Cu (Pe2)

In [A]: 800

D<sub>max</sub> [m]: 9

D [m]: 7

BUSBAR [kg/m]: 23,3

BOX WEIGHT 1 [kg]: 18

BOX WEIGHT 2 [kg]: 12

$$H = 130 - \frac{23,3 \cdot 7 + (18 + 12)}{3 \cdot 4} = 113,9 \text{ mm}$$

TYPE OF BUSBAR: S-5C-AI (Pe1)

In [A]: 2000

D<sub>max</sub> [m]: 9X0,9=8,1

D [m]: 6

BUSBAR [kg/m]: 29,6

BOX WEIGHT 1 [kg]: 18

BOX WEIGHT 2 [kg]: 12

$$H = 130 - \frac{29,6 \cdot 6 + (18 + 12)}{3 \cdot 6} = 118,5 \text{ mm}$$

## 3.3.2 Wall and floor drilling

Drill the required floor and wall holes for fixing all the brackets

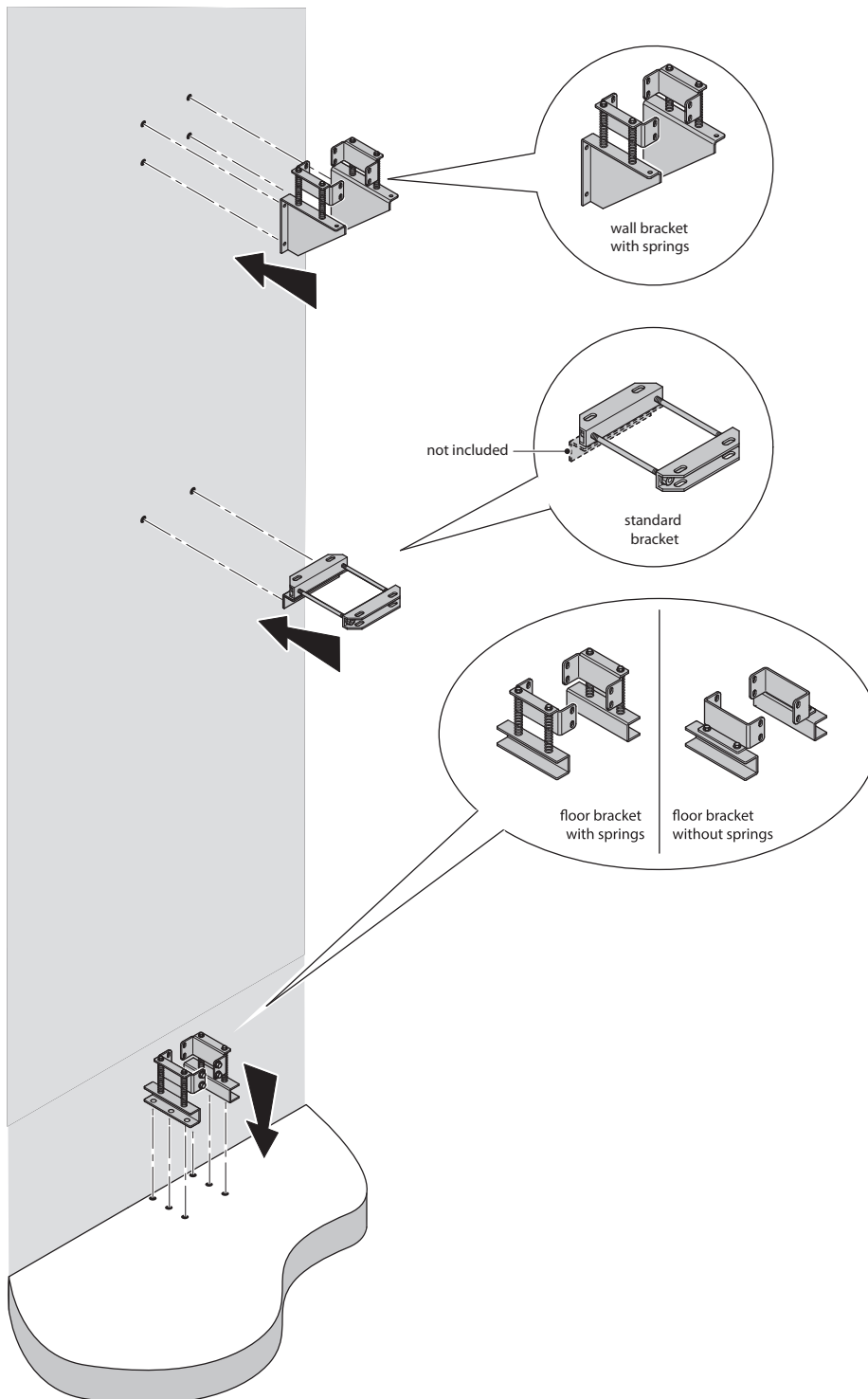

Below are the procedures for drilling the holes for each type of bracket.

## 3.3.2.1 Floor bracket with/without springs

The bottom supports (dashed shapes) are not included with the brackets, but are available to order.

### Floor bracket with springs (type C)

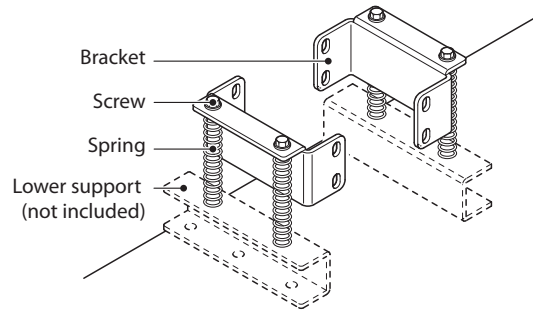

### Floor bracket without springs (type D)

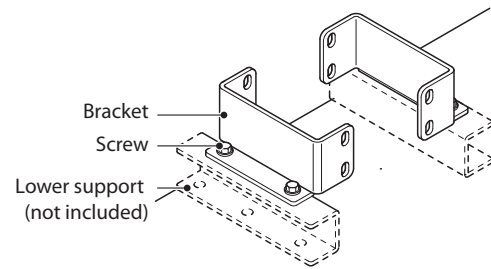

1) On the floor, mark the holes of the bottom supports at the point where the busbar must be secured.

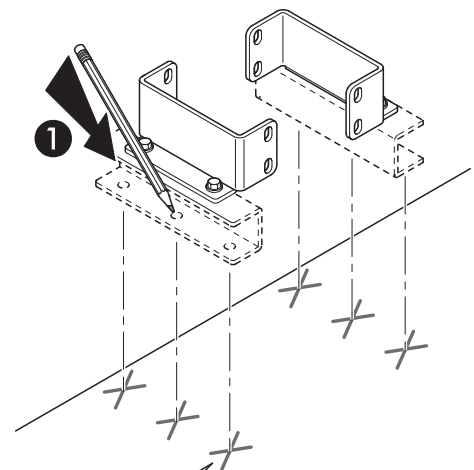
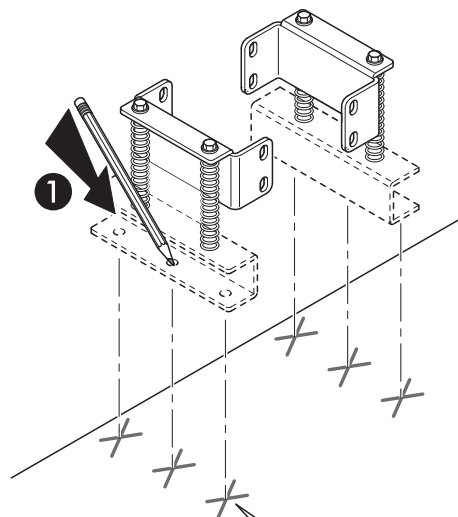

2) Drill the floor at the marked positions.

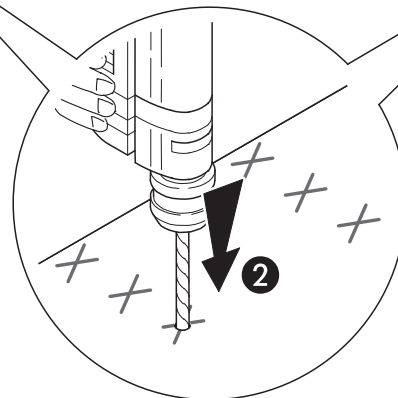

## 3.3.2.2 Wall bracket with springs and anti-seismic bracket

### Wall bracket with springs (type A)

#### Section line of over 4 m

In the lowest point **Type A** vertical bracket if secured **to the wall**

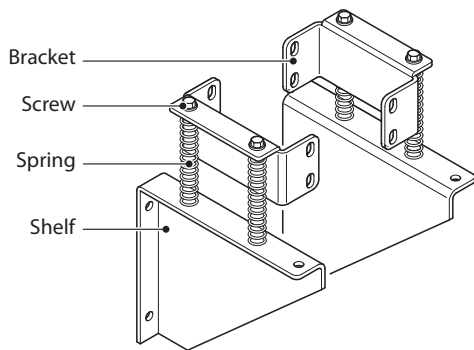

### Anti-seismic wall bracket (type B)

#### Section line between 2 and 4 m

In the lowest point **Type B** vertical bracket if secured **to the wall**

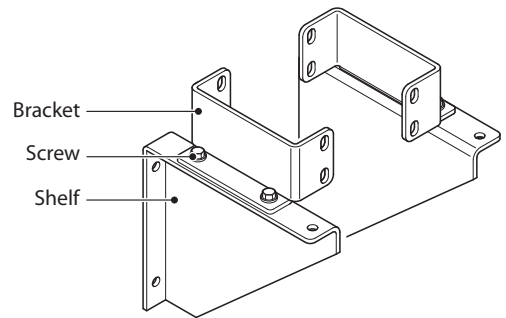

#### WARNING

Do not position the bracket nearby branching, joining ports and tap offs.

- 1) Set the bracket position on the busbar.

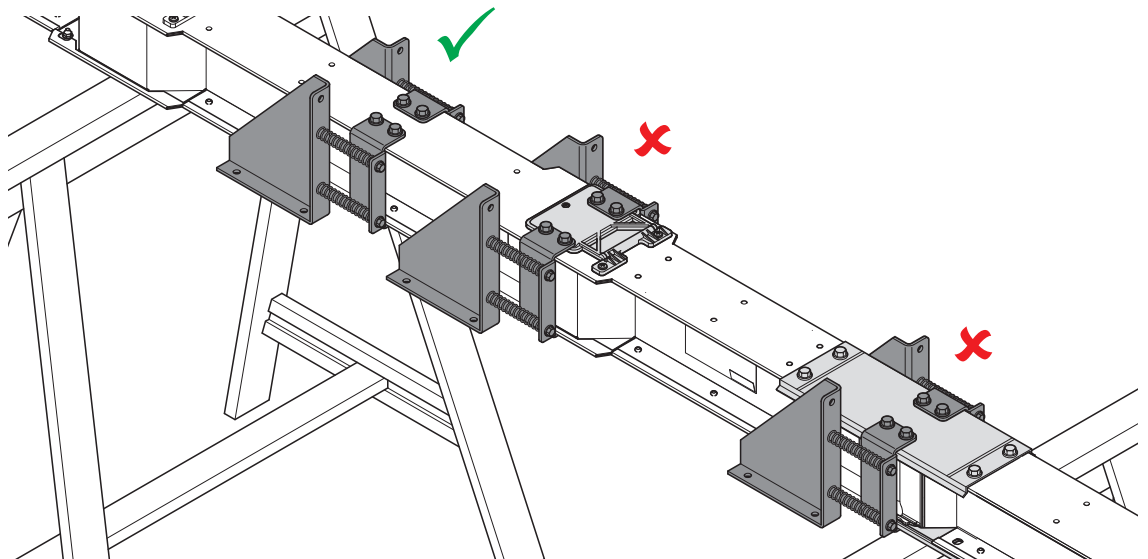



2) Place the bracket on the busbar at the fixing position and mark the upper side of the shelf.

**Wall bracket with springs (type A)**

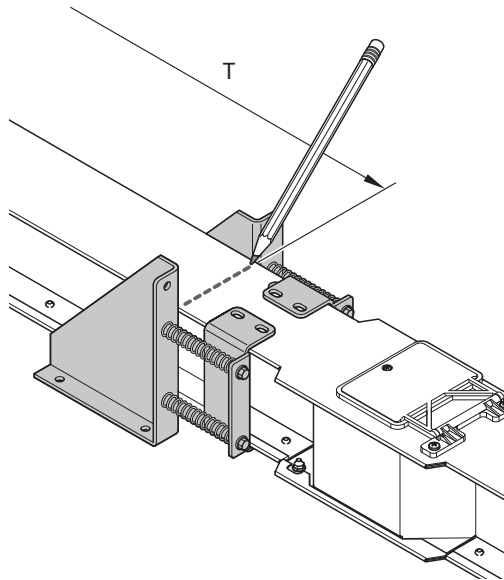

**Wall bracket (type B)**

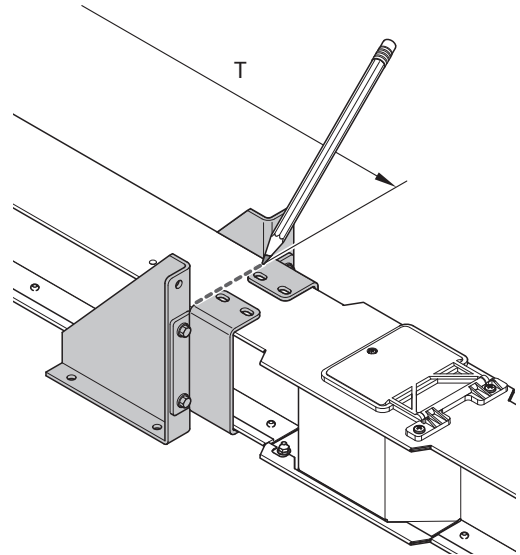

**WARNING**

The measurement must be from the busbar cap and not the bars.

3) Measure the distance T from the mark just made to the bottom cap of the component.

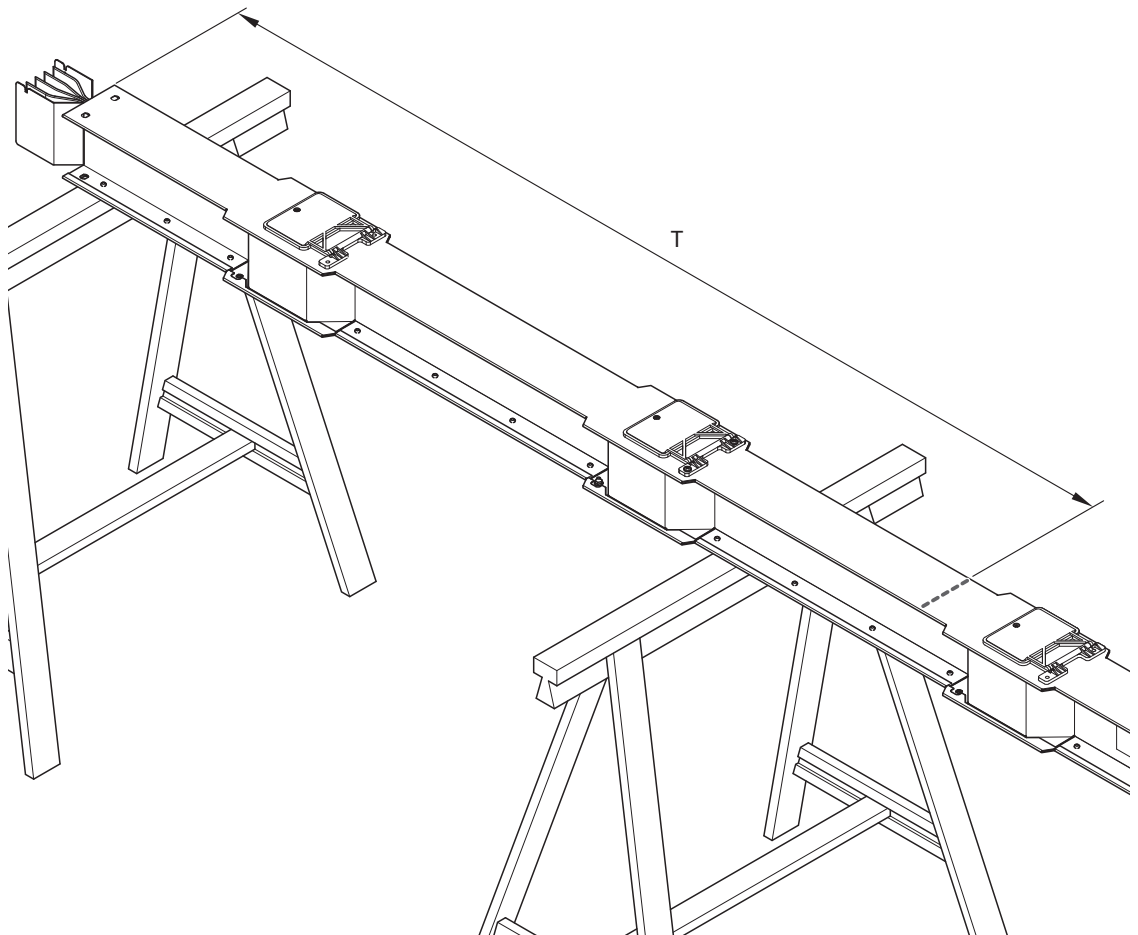

# ZUCCHINI

4) On the wall, mark the position Z of the two upper holes of the shelves (indicated in the magnified view), calculated as follows:  
 $Z = T - 19 + 270$   
(measurements in millimeters).

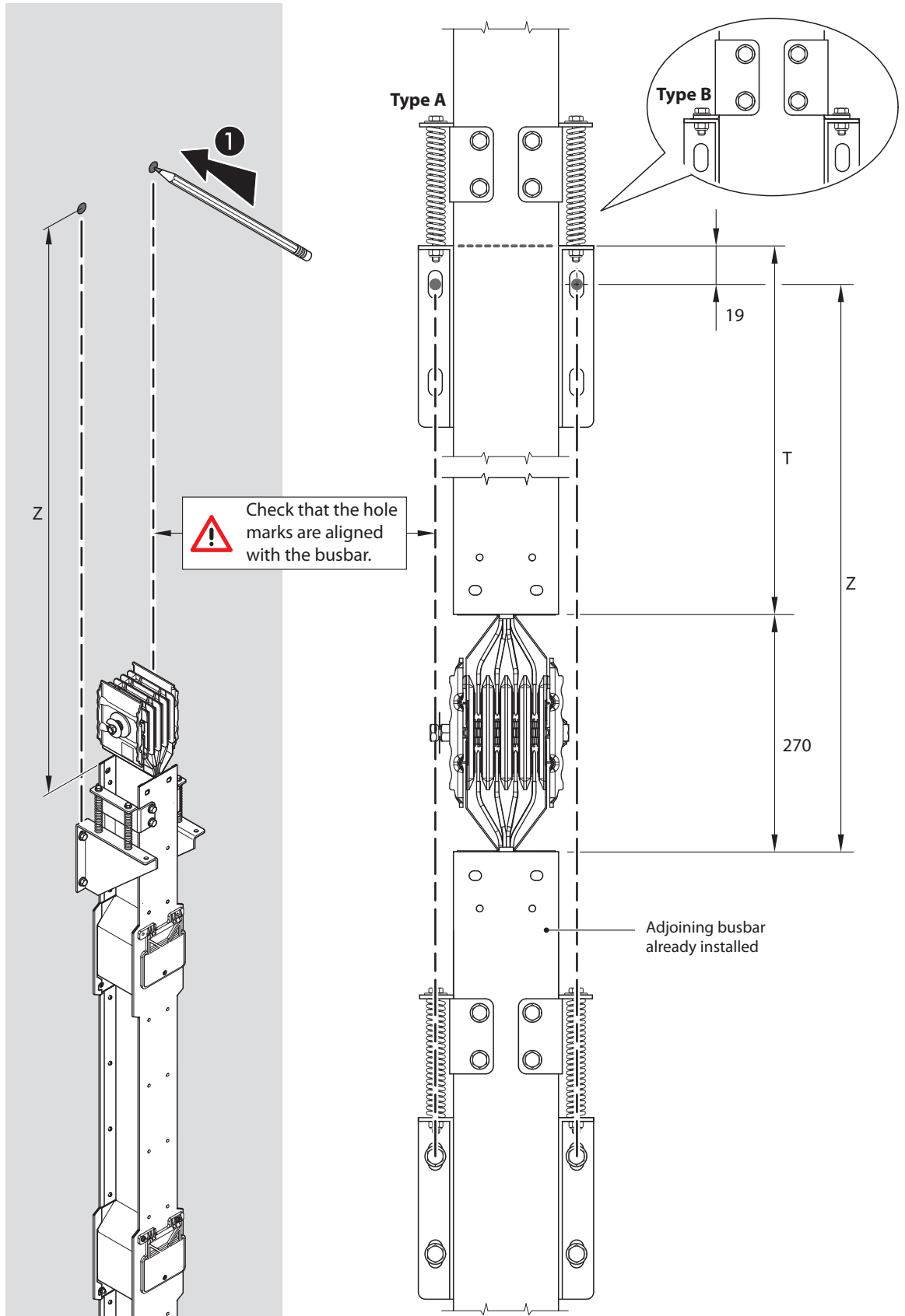

**⚠ WARNING**

The Z value must be measured from the upper cap of the already installed adjoining busbar.

5) On the wall, mark the positions of the bottom holes of the shelves, in accordance with the values below.

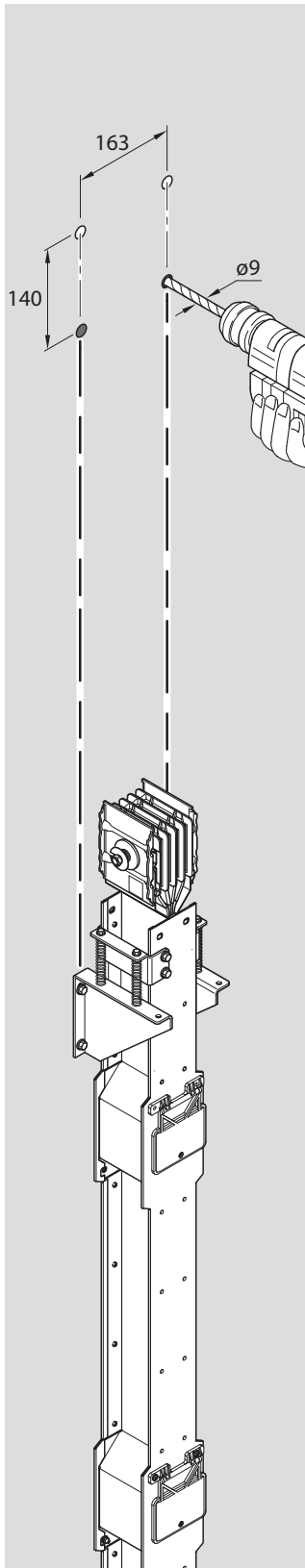

6) Drill the holes at the marked positions. Check that the hole marks are aligned with the busbar.

**Wall bracket with springs (type A)**

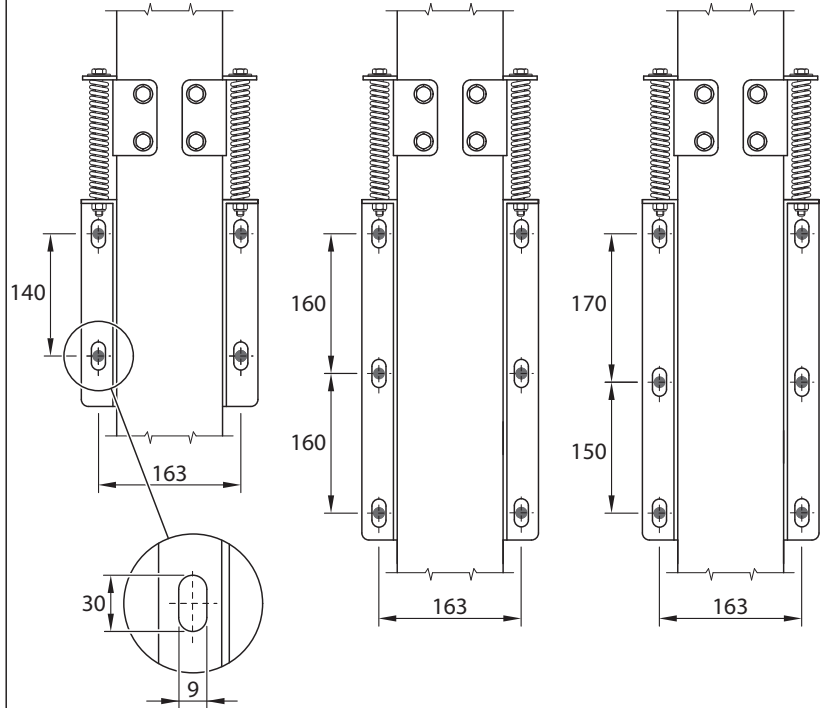

**Bracket (type B)**

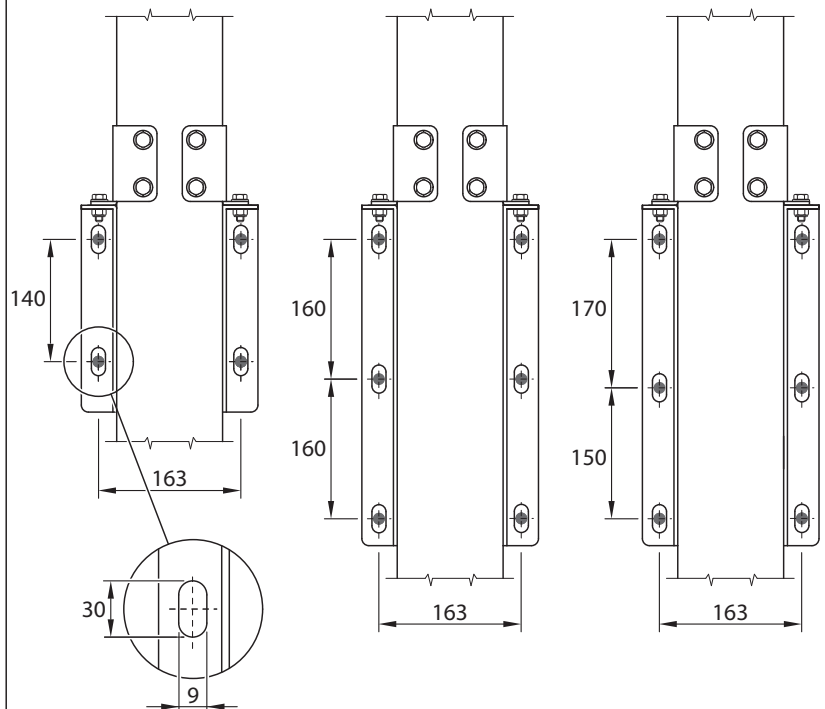

### 3.3.2.3 Standard bracket

The bottom support (dashed shape) is not supplied.

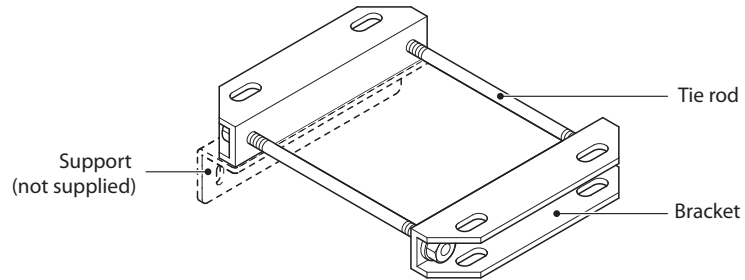

- 1) Set the bracket position on the busbar.



**WARNING**

Do not position the bracket nearby branching and joining ports.

- 2) Place the bracket on the busbar and mark its upper side.

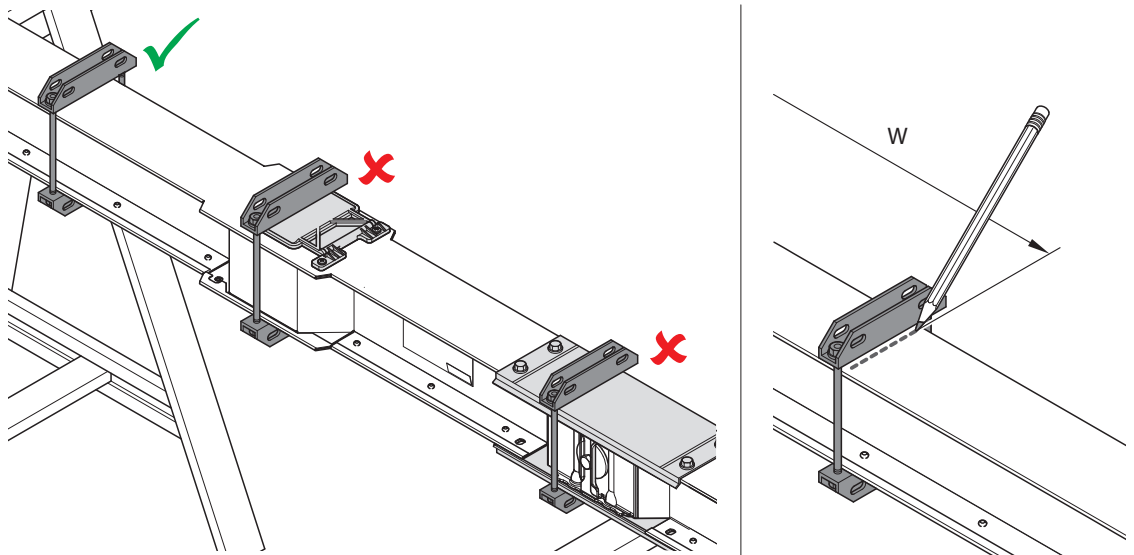

- 3) Measure the distance  $W$  from the mark just made to the bottom cap of the busbar.



**WARNING**

The measurement must be from the busbar cap and not the bars.

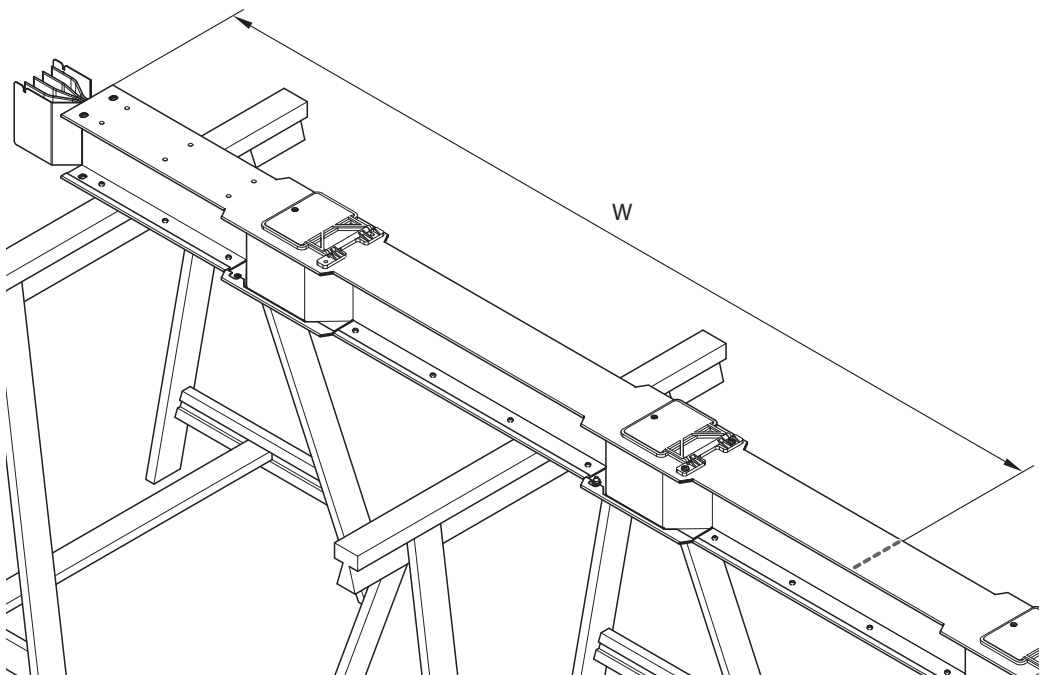

4) On the wall, mark the position U for fixing the bottom support, calculated as follows:  
 $U = W + 270 - 40 - X$   
(measurements in millimeters).



**WARNING**

The U value must be measured from the upper cap of the already installed adjoining busbar.

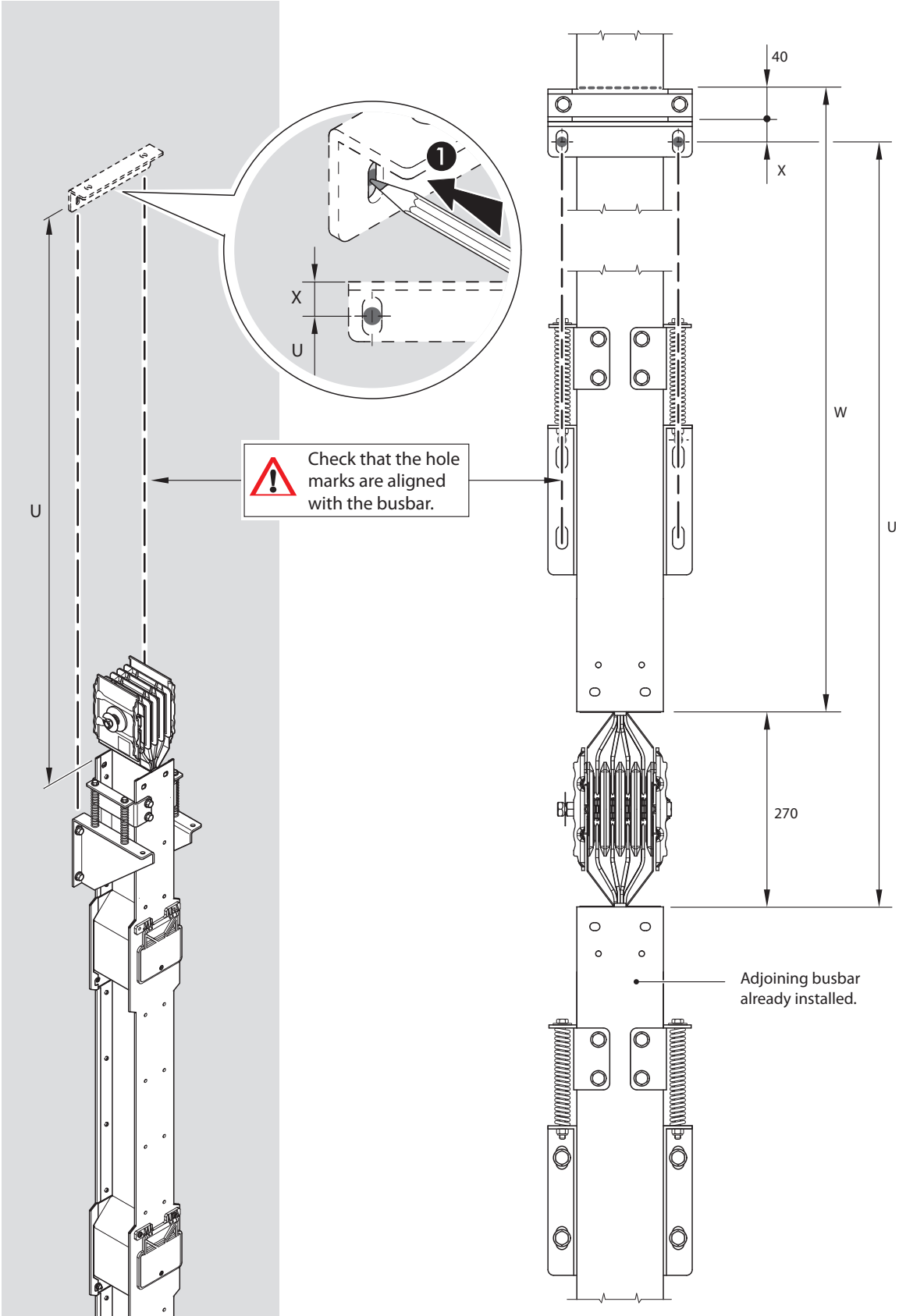

# ZUCCHINI

5) Drill the wall and fix the bottom bracket support.

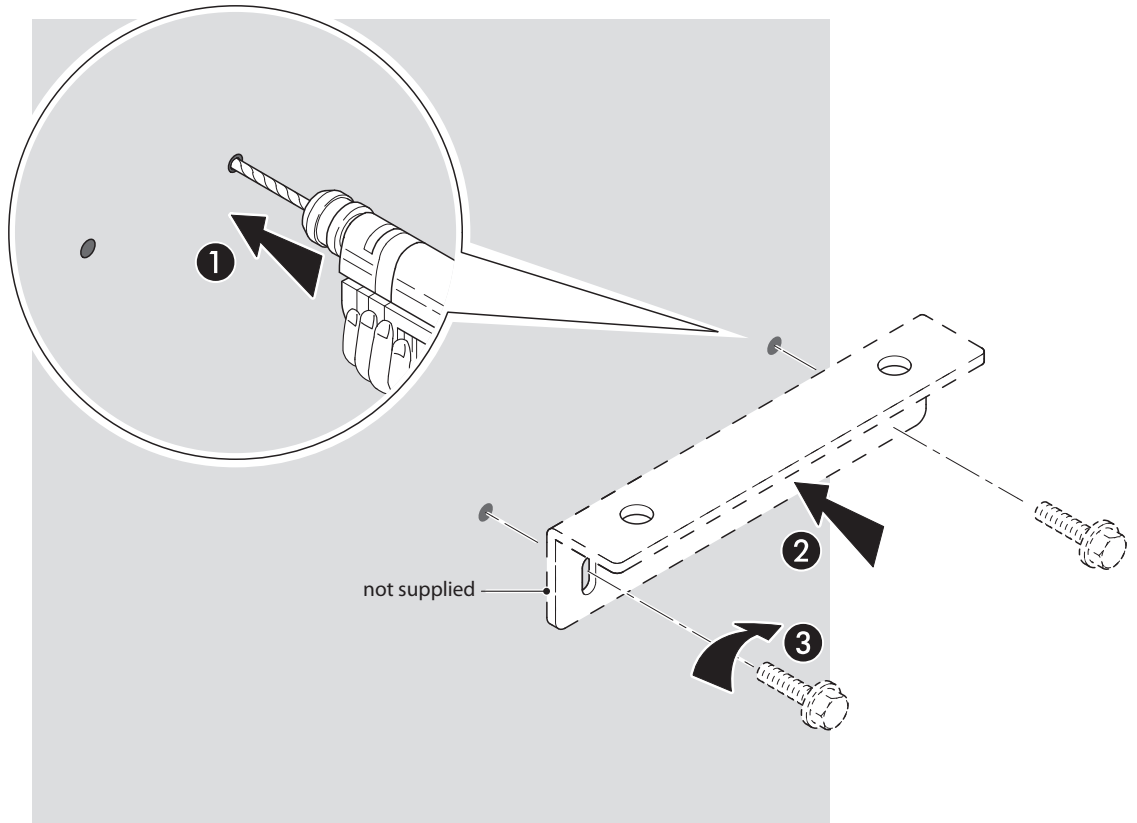

6) Attach the bracket to the bottom support.

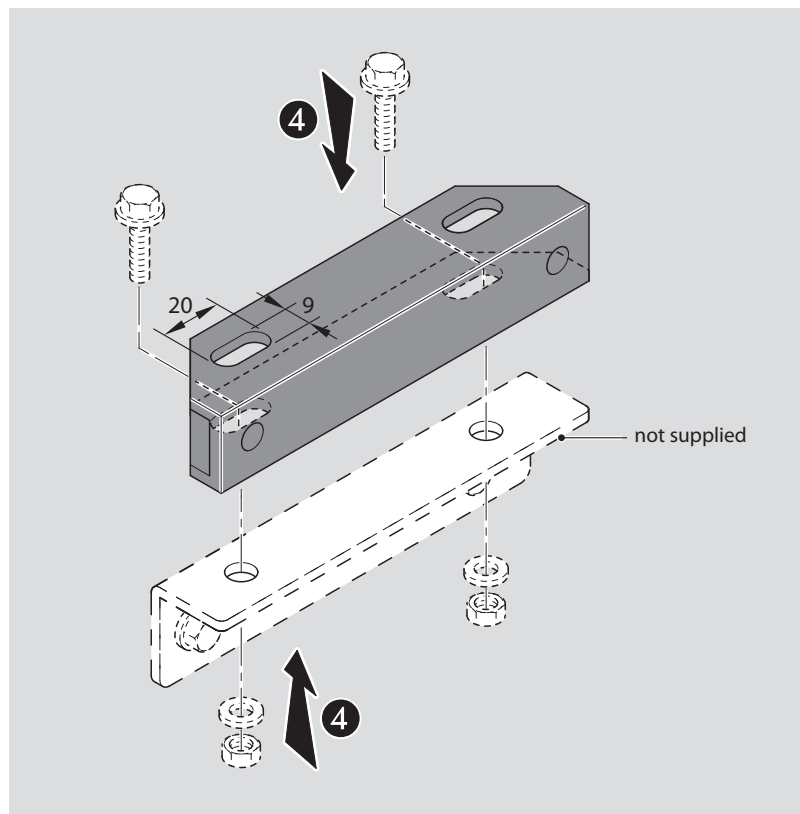

## 3.3.3 Attaching the brackets to the busbars

### 3.3.3.1 Floor bracket with springs

- 1) Mark the four bracket holes on the busbar in accordance with the following values:  
 $P = X + Y + H - 270 - 19$   
 (measurements in millimeters).

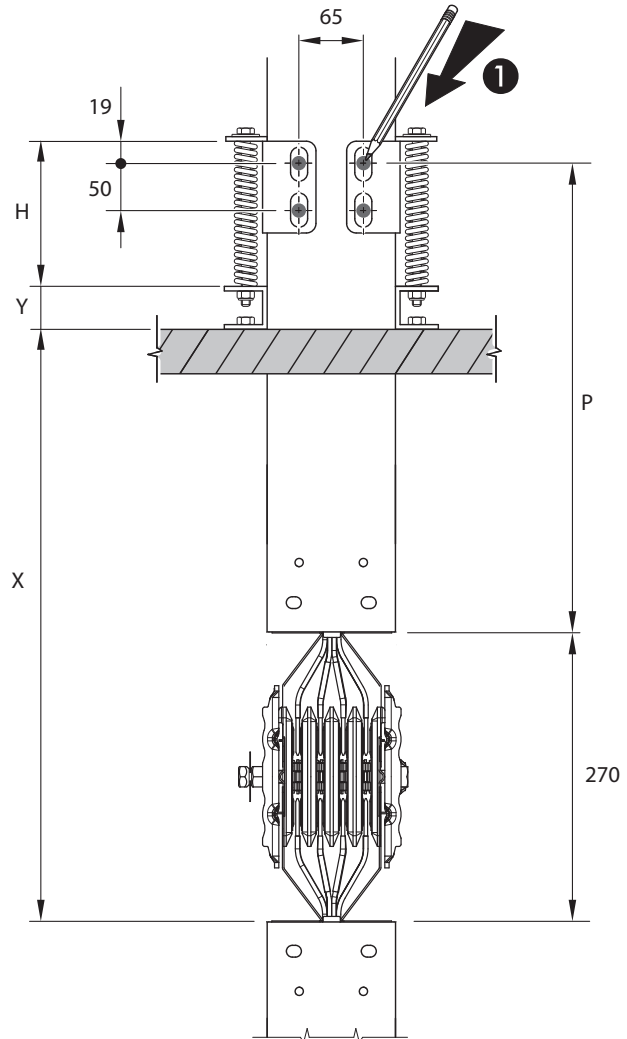
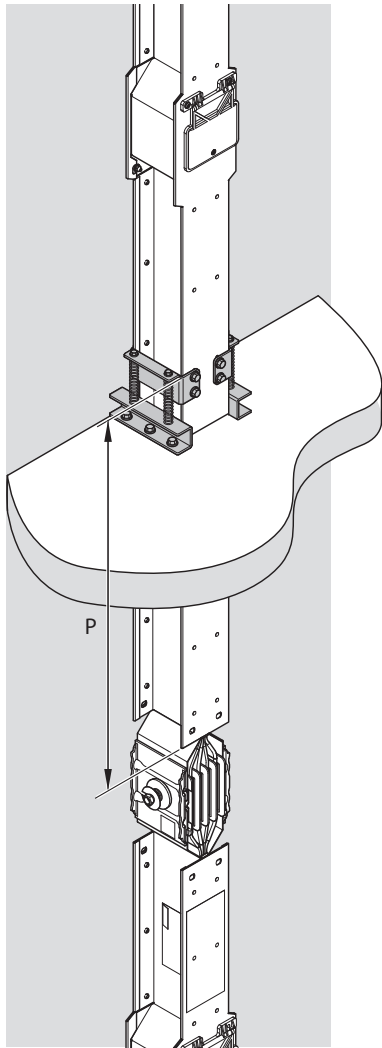

- 2) Drill the busbar at the four marks just made:  
 HOLE  $\varnothing = 9\text{mm}$ .

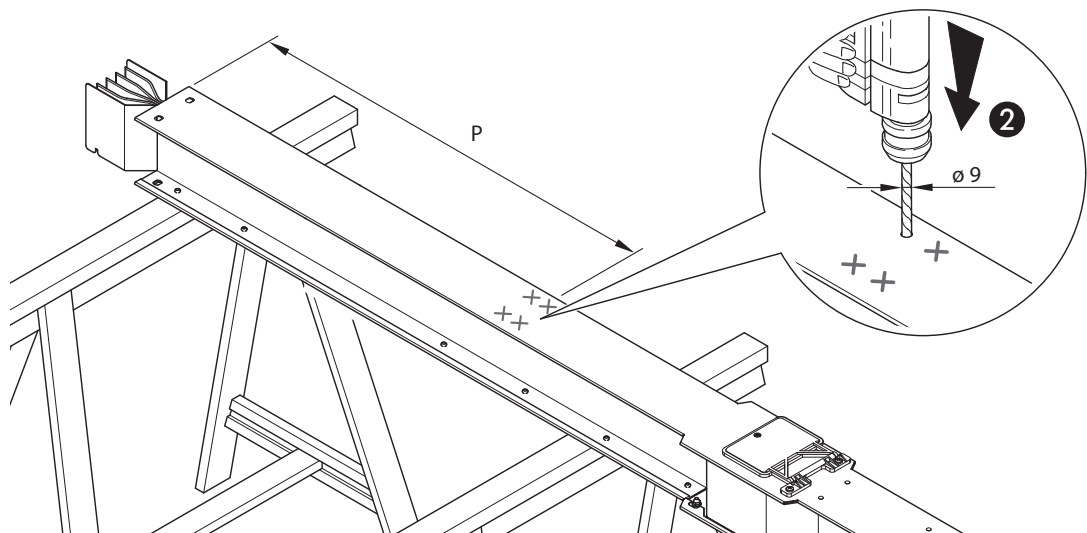

# ZUCCHINI

3) Screw the bracket to the busbar with a torque of 24 Nm.

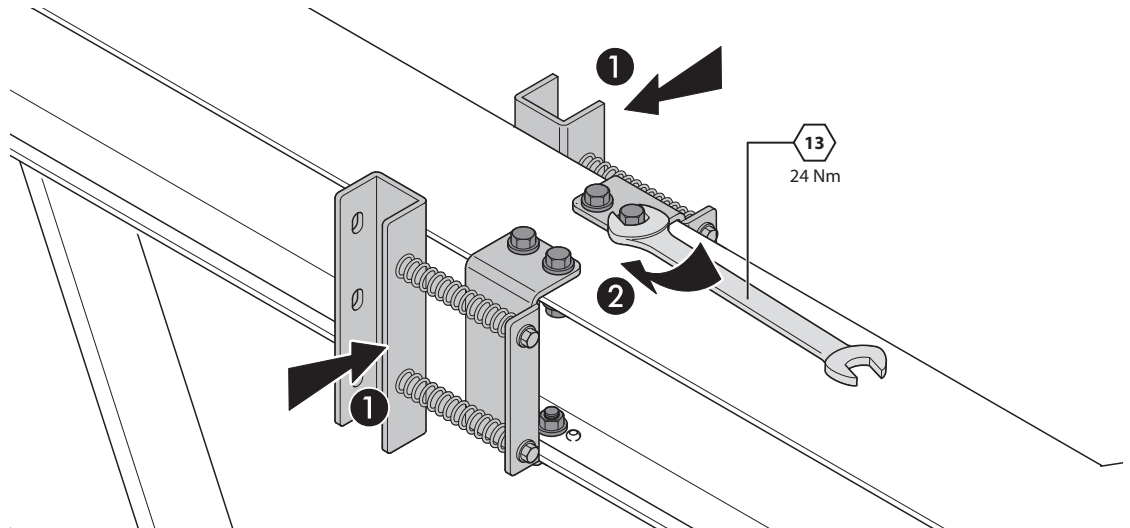

4) Tighten the nuts, bringing the spring to the CHARGING distance H as previously defined (page 38).

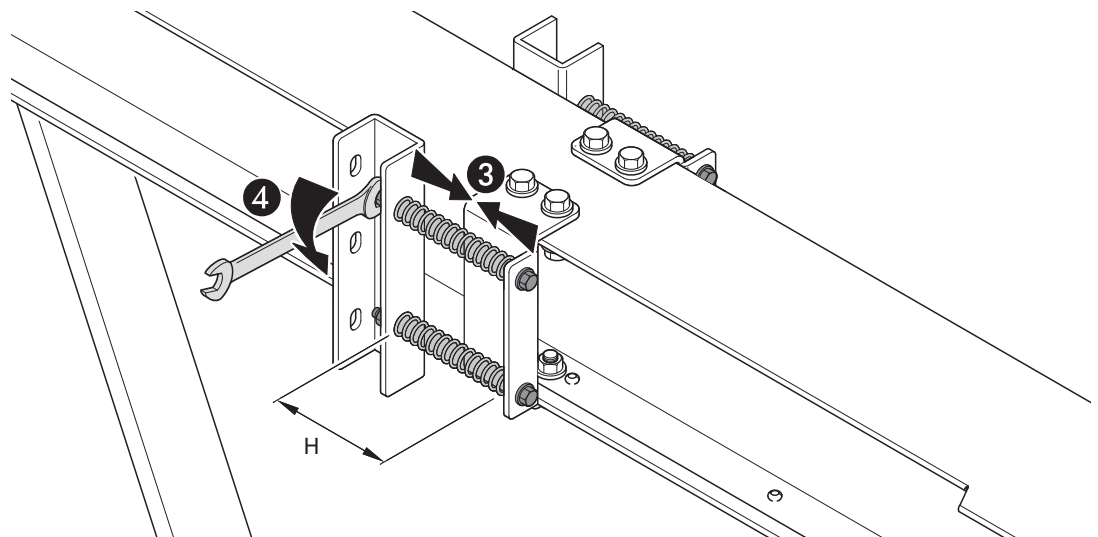



**3.3.3.2 Floor bracket without springs**

1) Mark the four bracket holes on the busbar in accordance with the following values:  
 $Q = X + Y + 69 - 270$   
 (measurements in millimeters).

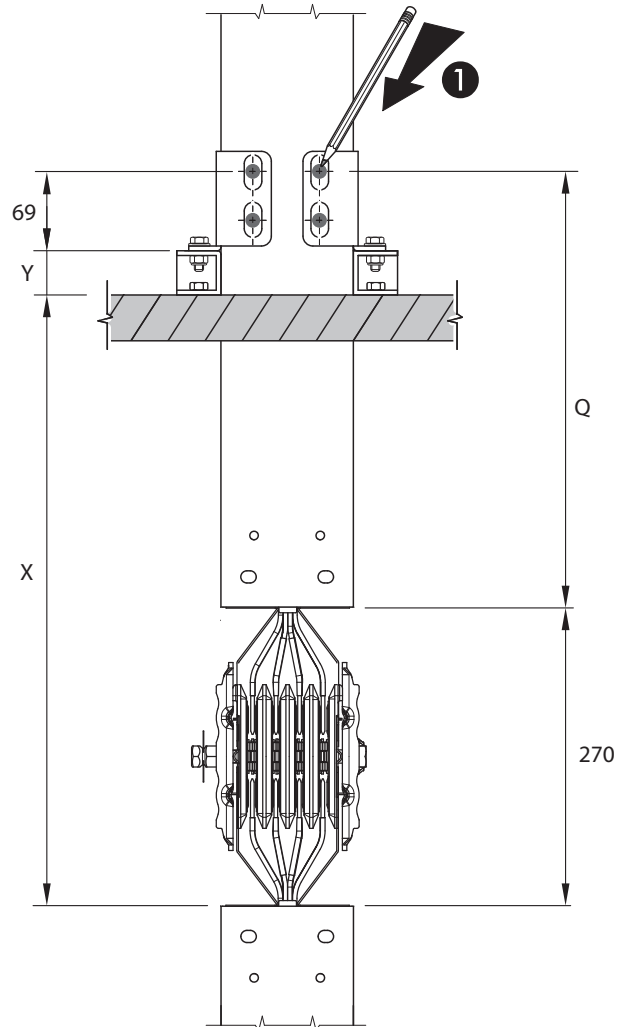
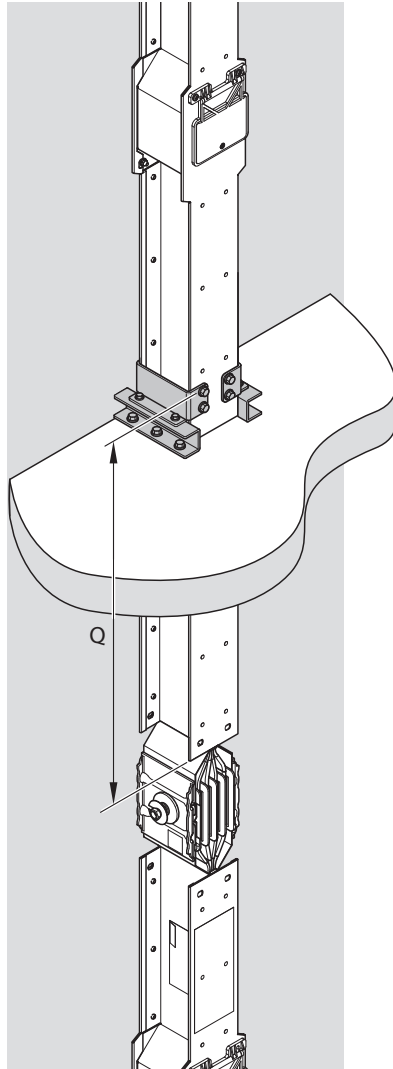

2) Drill the busbar at the four marks just made:  
 HOLE  $\varnothing = 9\text{mm}$ .

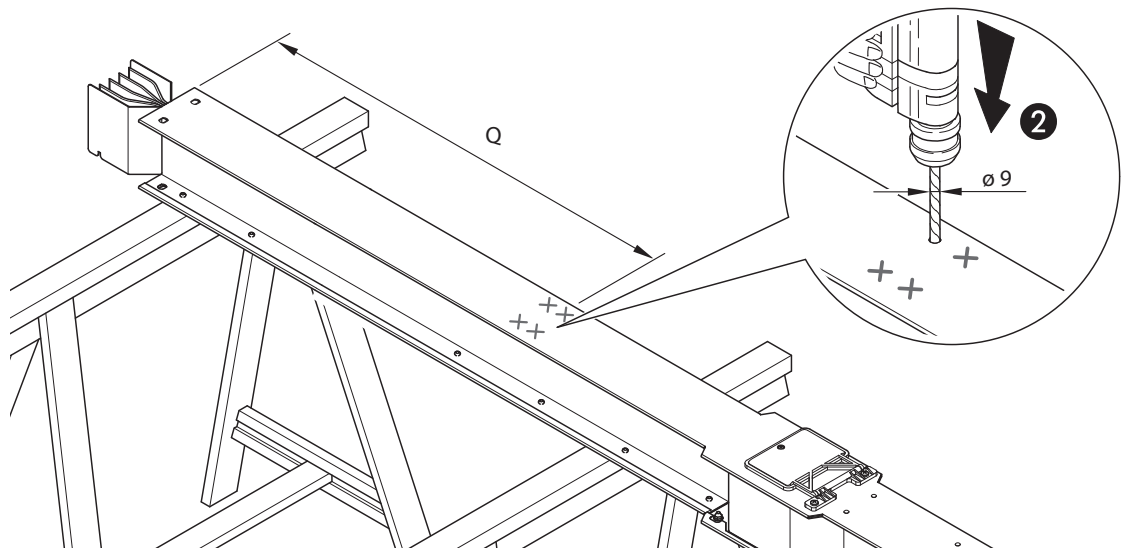

# ZUCCHINI

---

3) Screw the bracket to the busbar with a torque of 24 Nm.

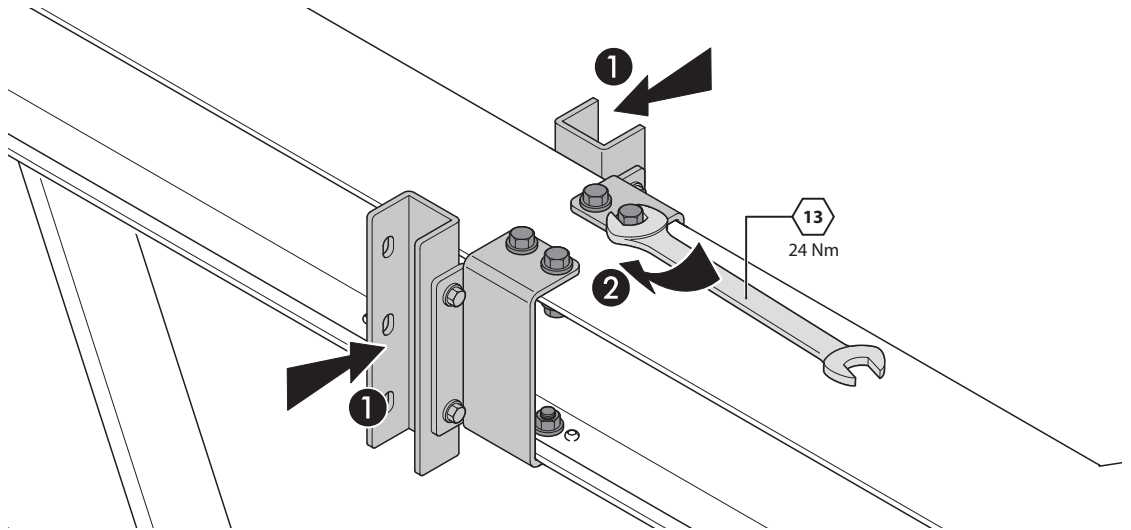

3.3.3.3 Wall bracket with springs

1) Mark the four bracket holes on the busbar, calculated as follows  $Y=T+H-19$  (measurements in millimeters).

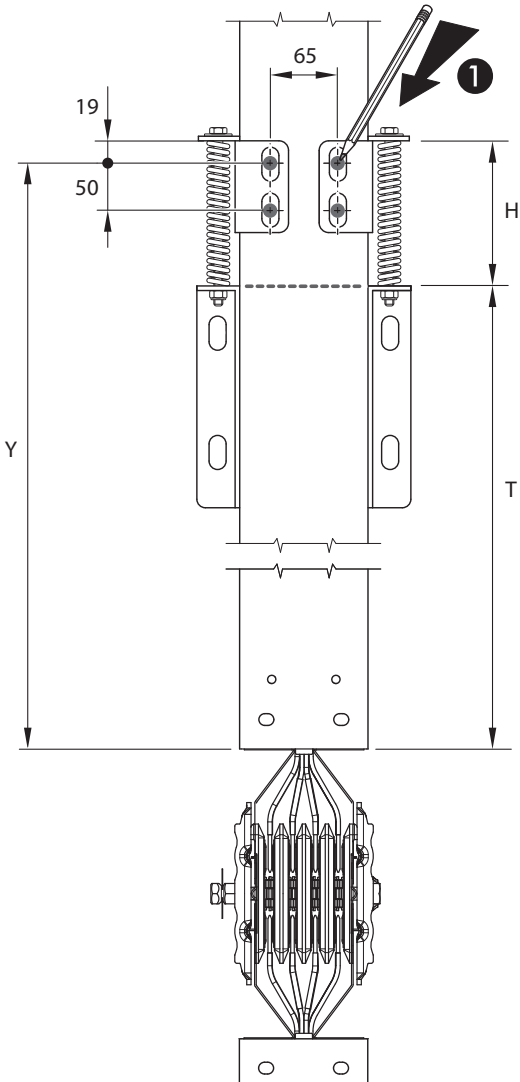
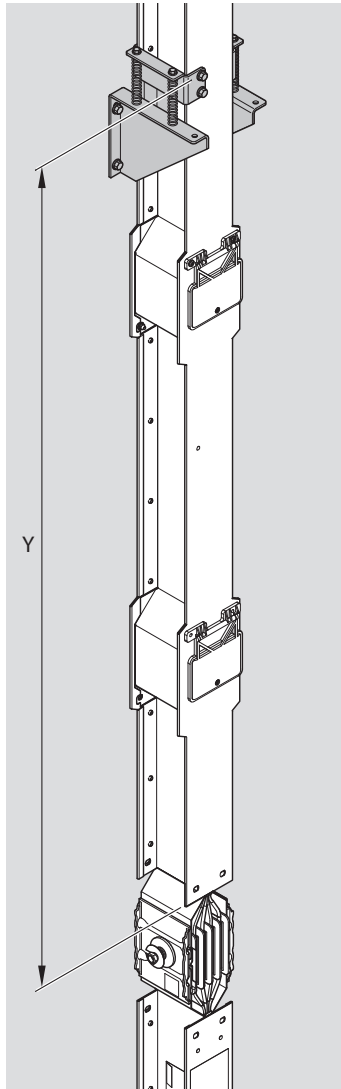

2) Drill the busbar at the marks just made: HOLE  $\varnothing = 9\text{mm}$ .

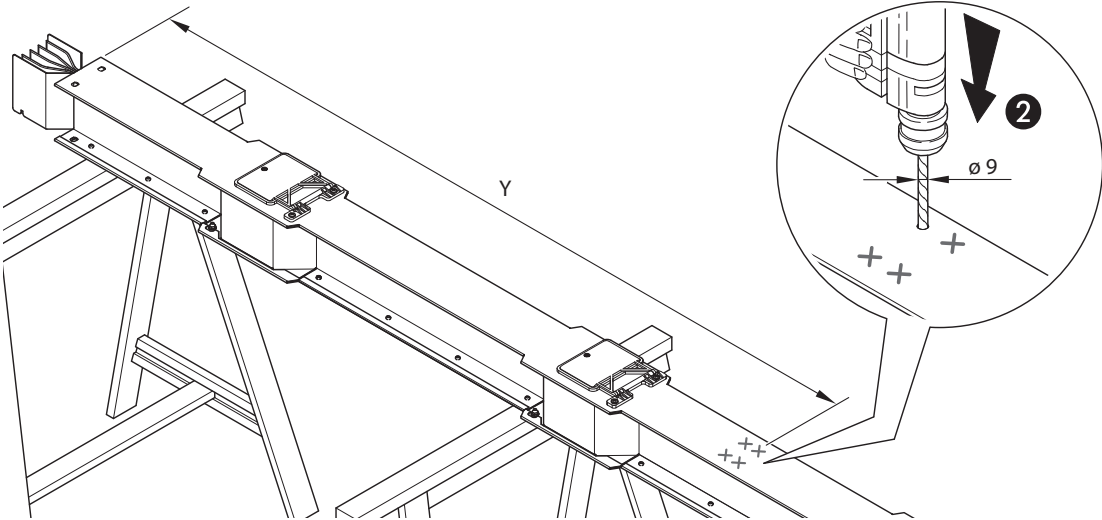

# ZUCCHINI

3) Screw the brackets to the busbar with a torque of 24 Nm.

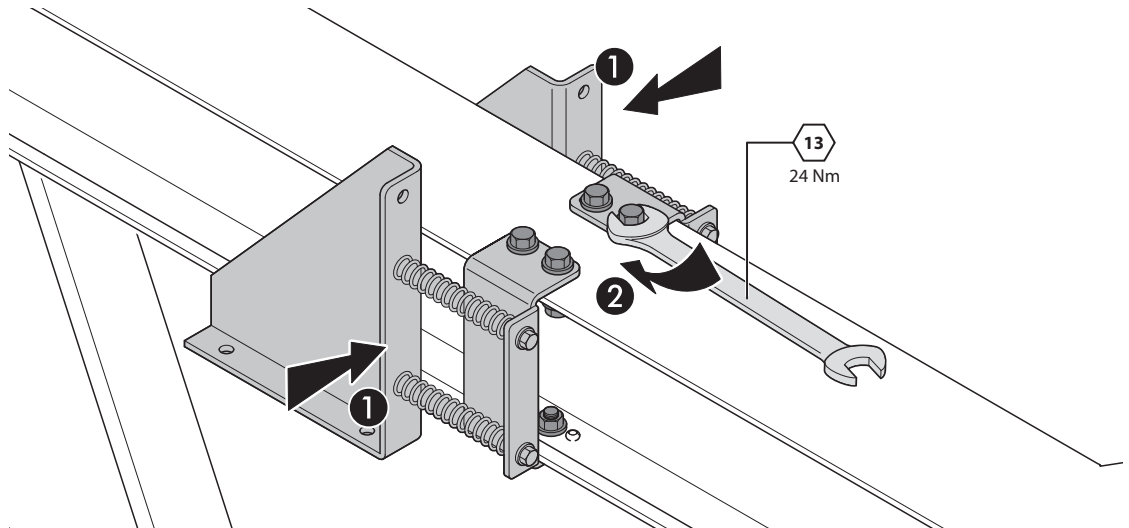

4) Tighten the nuts, bringing the spring to the CHARGING distance H as previously defined (page 35).

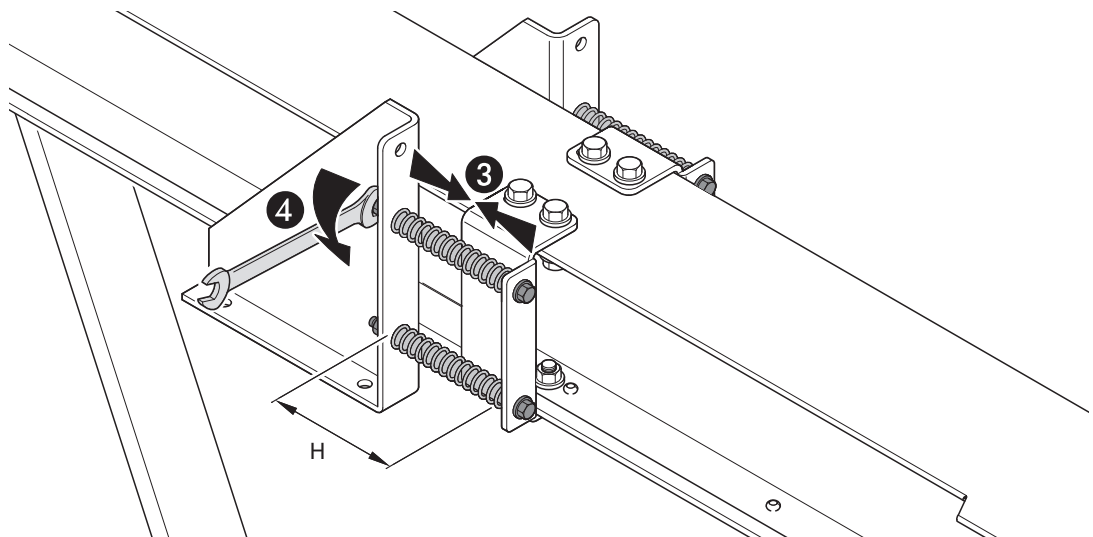

**3.3.3.4 Wall bracket without springs**

1) Mark the four bracket holes on the busbar, calculated as follows:  
 $Y = T + 69$ .  
 (measurements in millimeters).

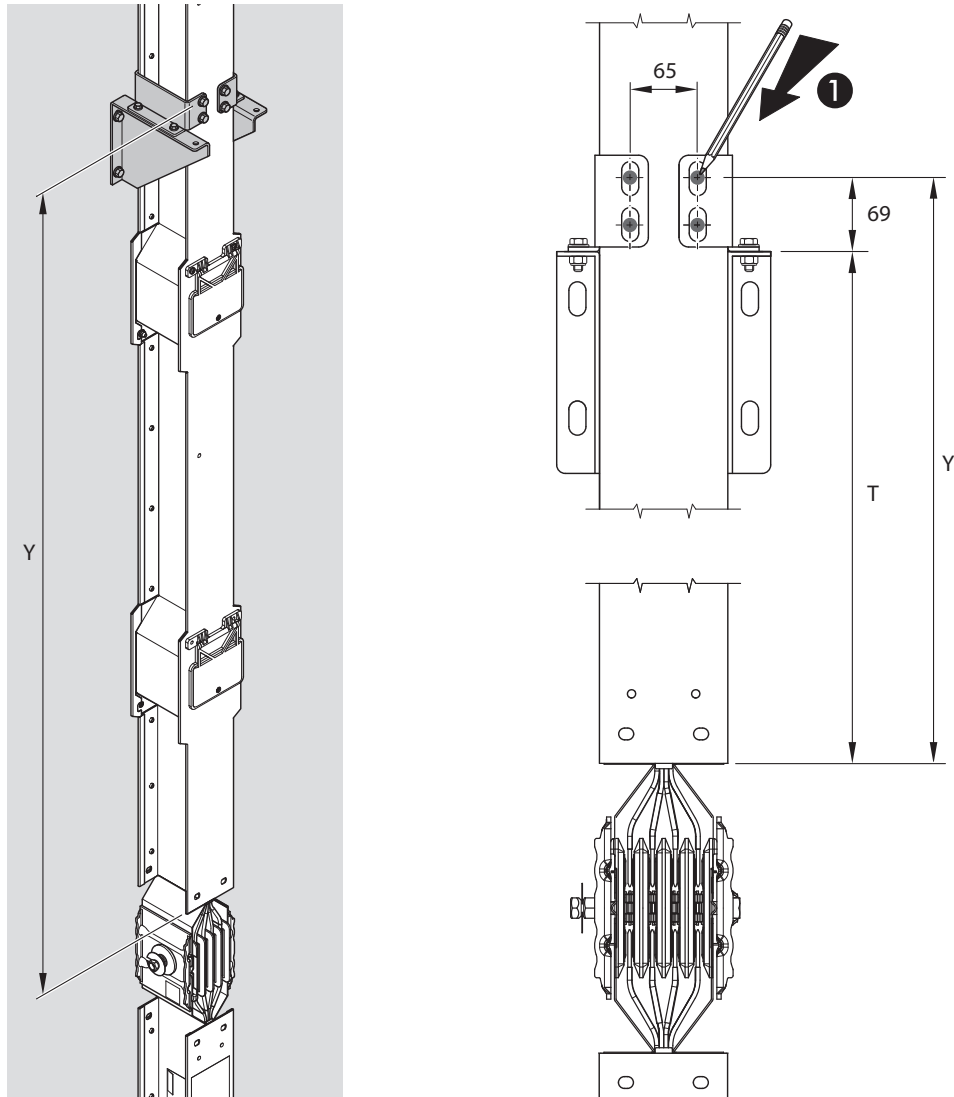

2) Drill the busbar at the marks just made:  
 HOLE  $\varnothing = 9\text{mm}$ .

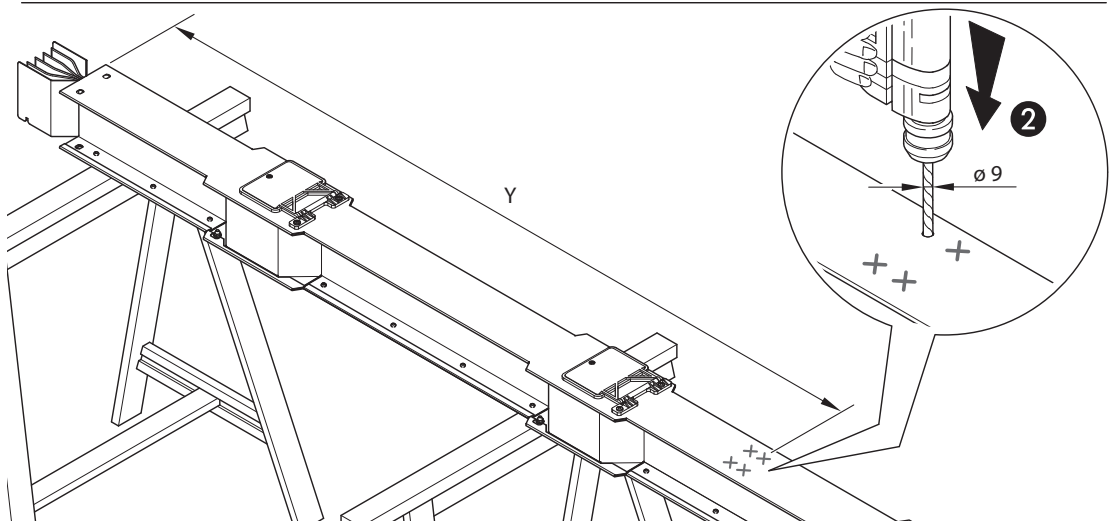

# ZUCCHINI

---

3) Screw the brackets to the busbar with a torque of 24 Nm.

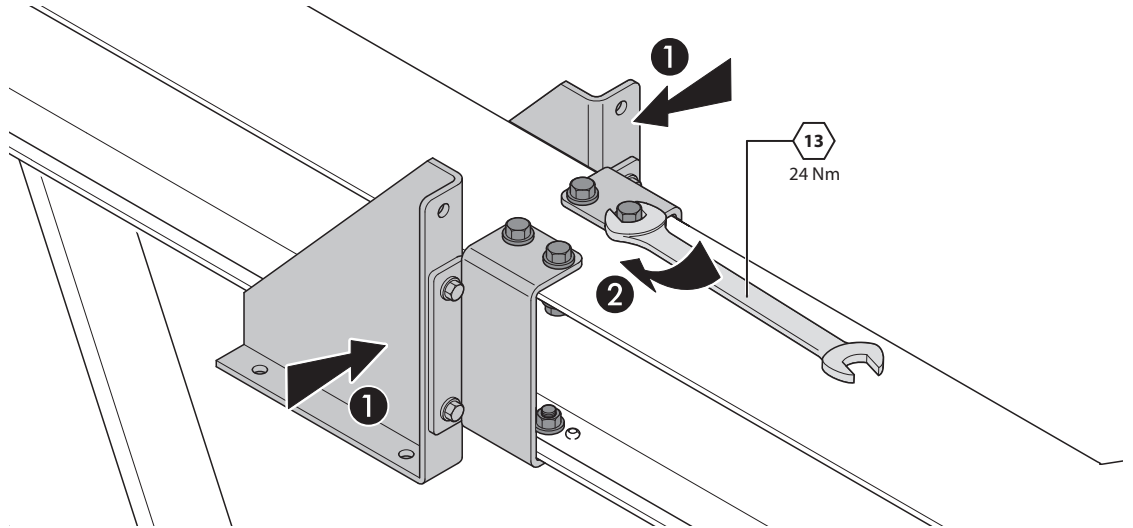

**3.3.4 Busbar mounting in line**  
**3.3.4.1 Floor bracket with/without springs**

1) Join the two components following the instructions below.

**Floor bracket with springs (type C)**

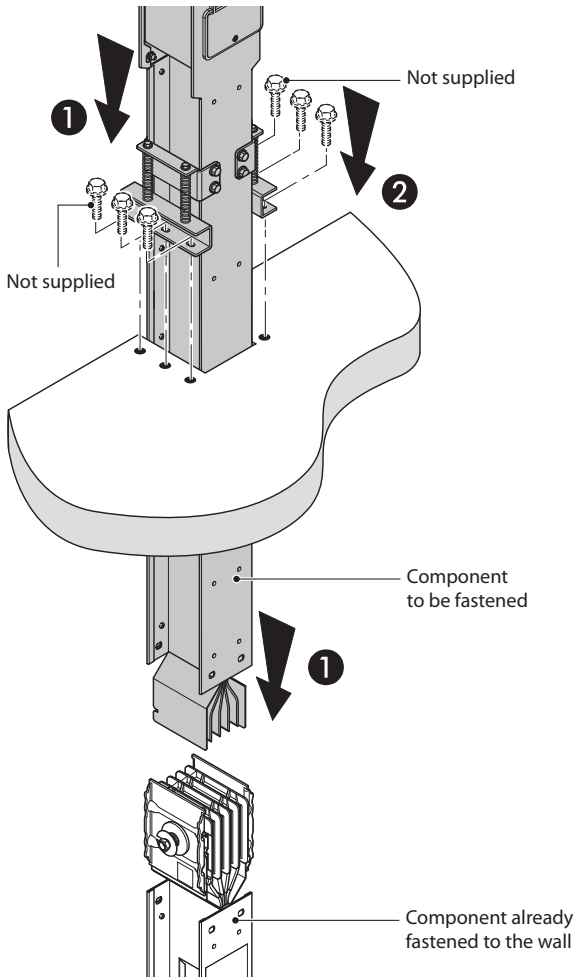

**Floor bracket without springs (type D)**

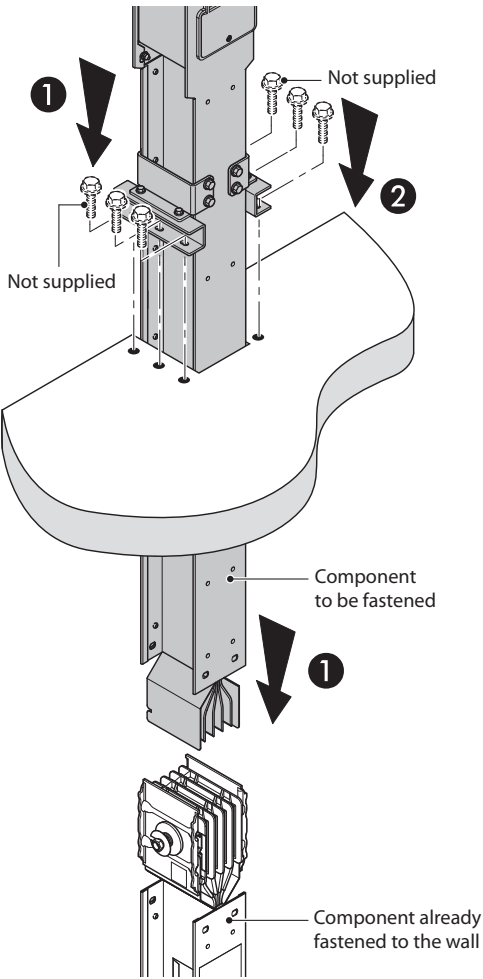

2) Match the bracket with the holes previously drilled on the floor and fasten with the screws.

3) For brackets with springs, unscrew the spring nuts.

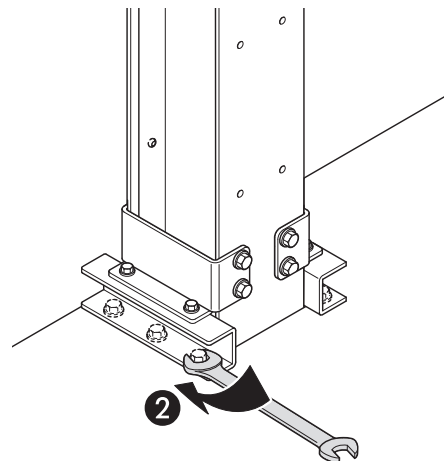
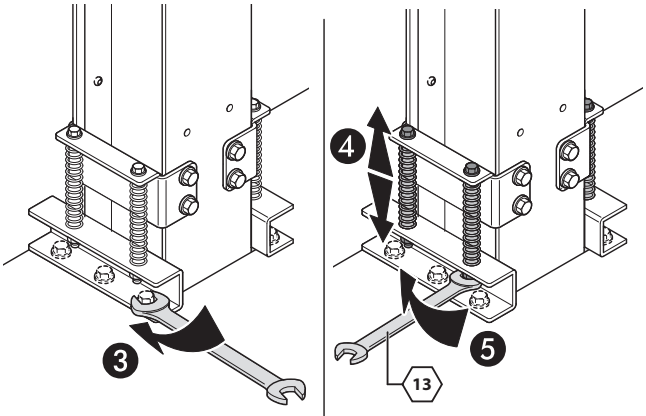

**! WARNING**  
 The nut must be fully unscrewed, therefore releasing the springs.

# ZUCCHINI

## 3.3.4.2 Wall bracket with springs and anti-seismic bracket

1) Join the two components following the instructions below.

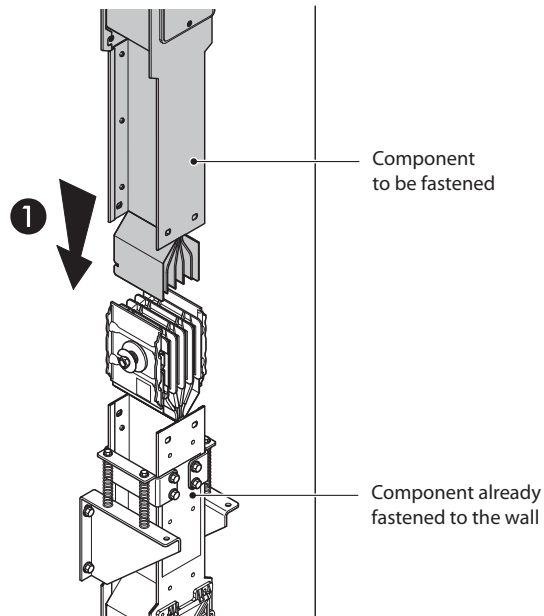

2) Match the the bracket with the holes previously drilled on the wall and fix with the screws

### Wall bracket with springs (type A)

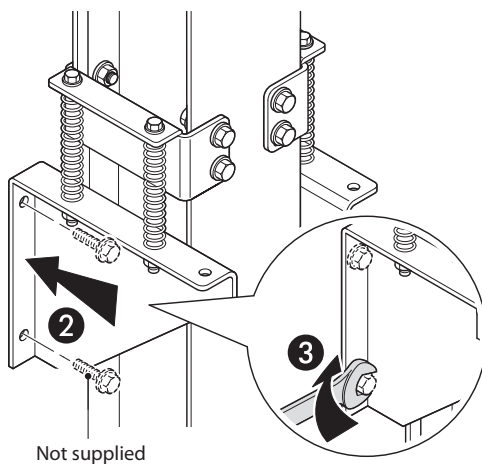

### Anti-seismic bracket (type B)

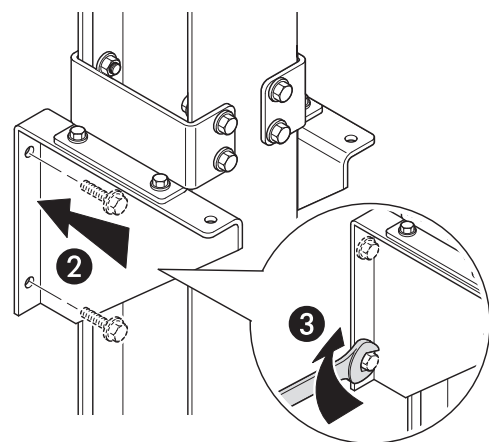

3) For brackets with springs, unscrew the spring nuts

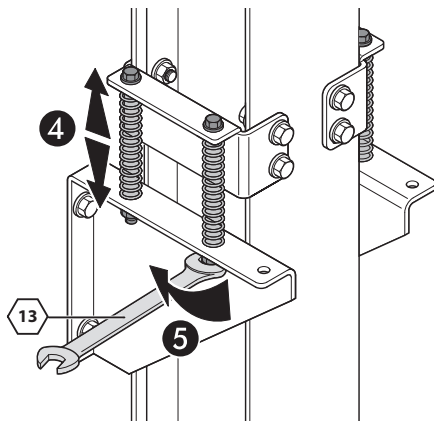

**WARNING**

The nut must be fully unscrewed, therefore releasing the springs.



### 3.3.4.3 Standard bracket

1) Using the screws supplied, attach the bracket to the one already attached to the support.

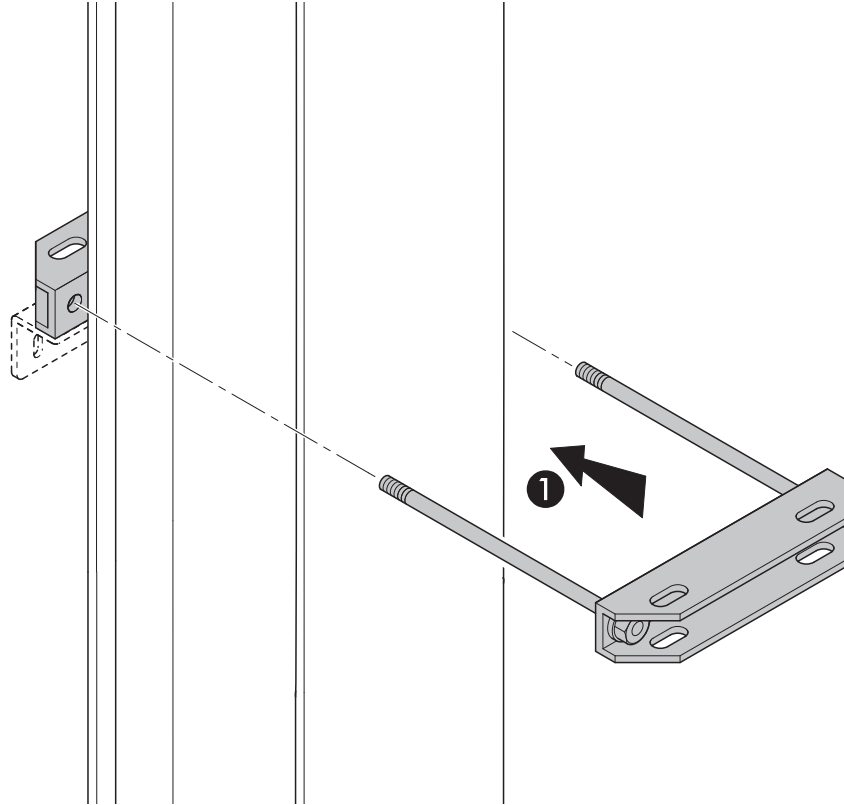

2) Tighten the screw with a torque of 15 Nm.

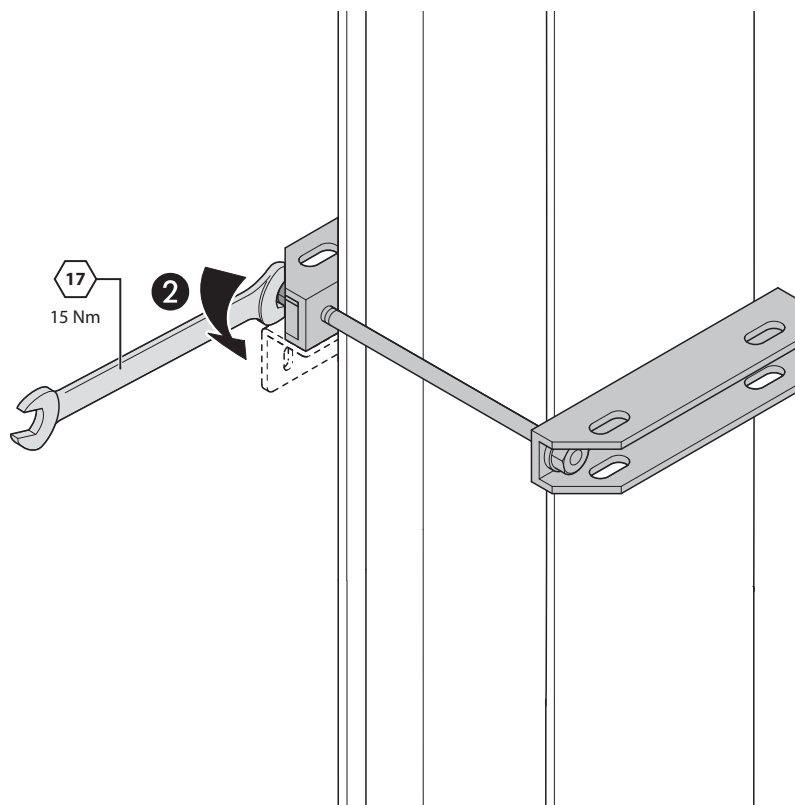

# ZUCCHINI

## 3.3.5 Joint installation

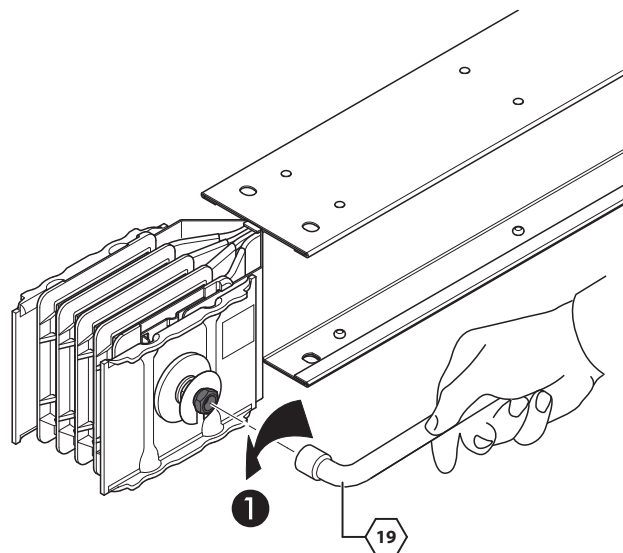
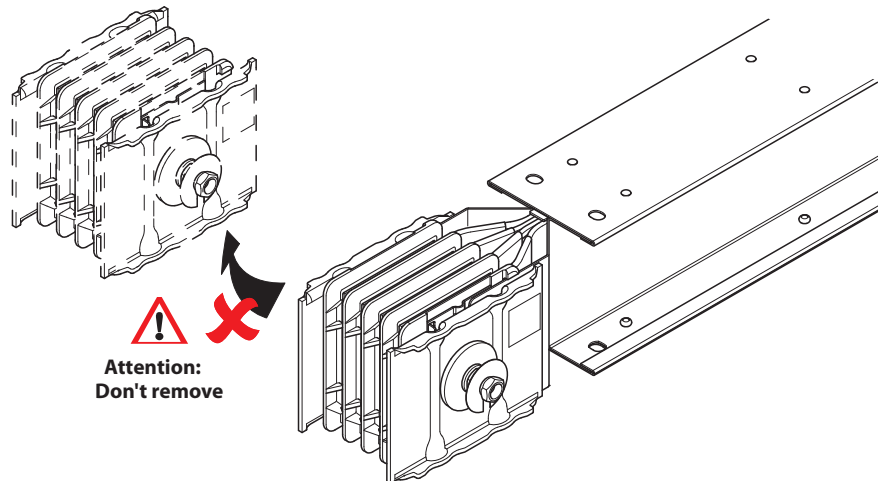

**! WARNING**

Remove residues with mild reagents not corroding or creating abrasion on surface treatment (zinc, tin, silver coating) or on contact surface (copper).

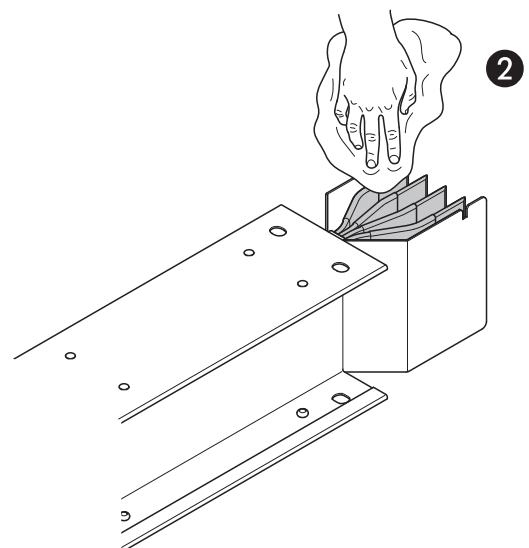

**⚠ DANGER**

The following operations must be carried out with the voltage disconnected.

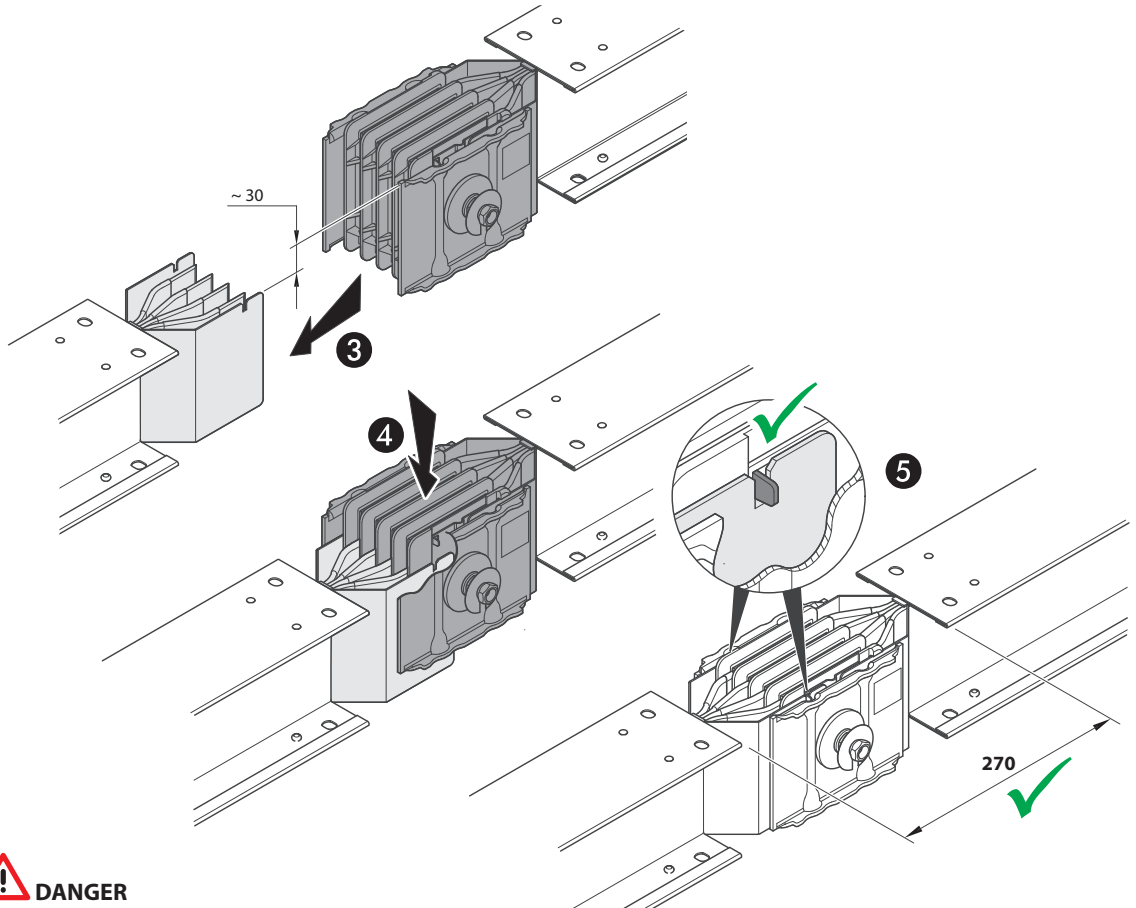

**⚠ DANGER**

**Hazard of short circuit**

- It is mandatory to correctly align all path components, joint blocks and PE conductors .
- It is mandatory to correctly position, between the fishplates, all path components conductors and the metallic side of the PE conductor between the fishplates.

**Failure to follow these instructions will result in death or serious injury.**

The continuity of the PE conductors is established by the enclosure of the path component. You must check the correct position of the components, joint blocks, and PE conductors and the continuity of the PE conductors through the joint block:

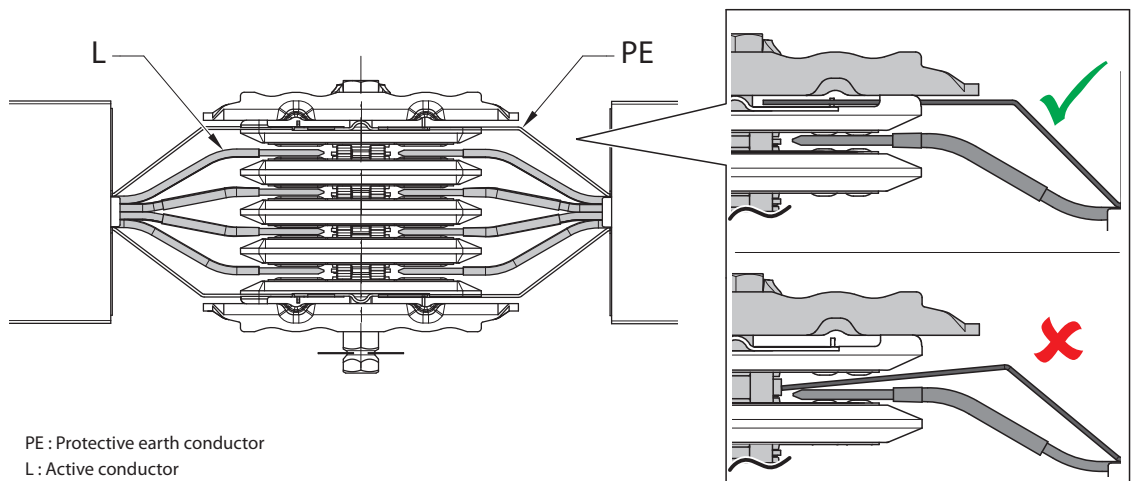

PE : Protective earth conductor  
L : Active conductor

# ZUCCHINI

---



**DANGER**

**LOSS OF IP55 PROTECTION RATING**

The path components must be correctly aligned.

**Failure to follow these instructions can result in equipment damage.**

**The alignment must be checked on both sides of the path components:**

Check the alignment on the loop of the path components:

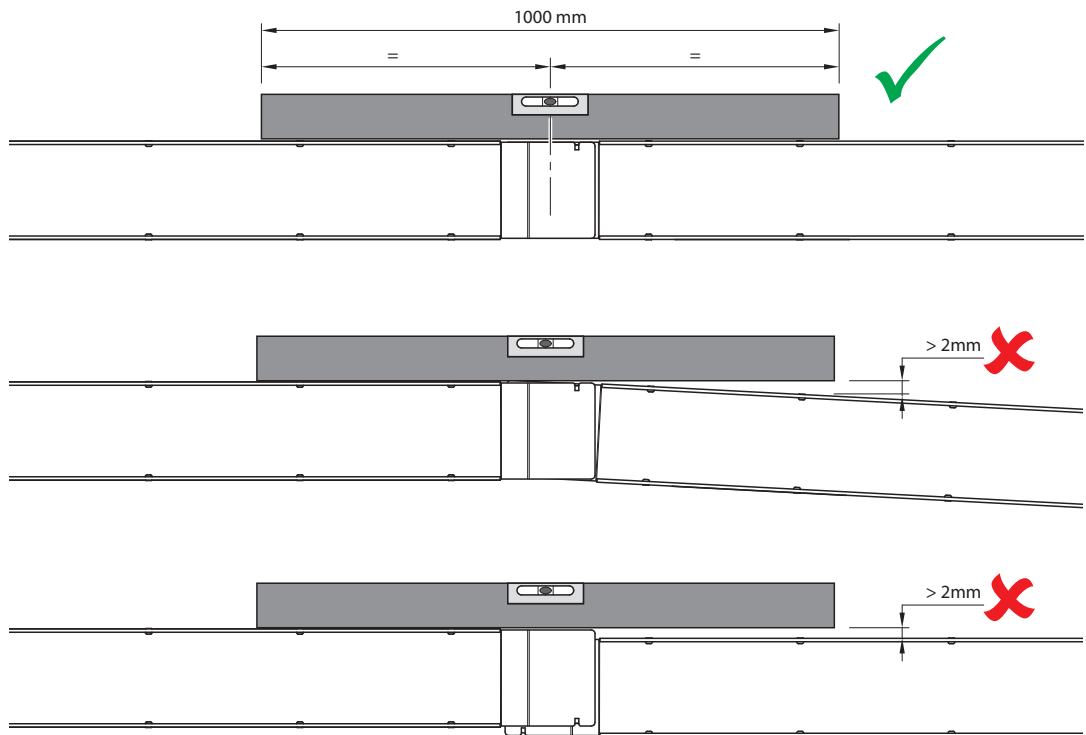

Check alignment on the side of the path components:

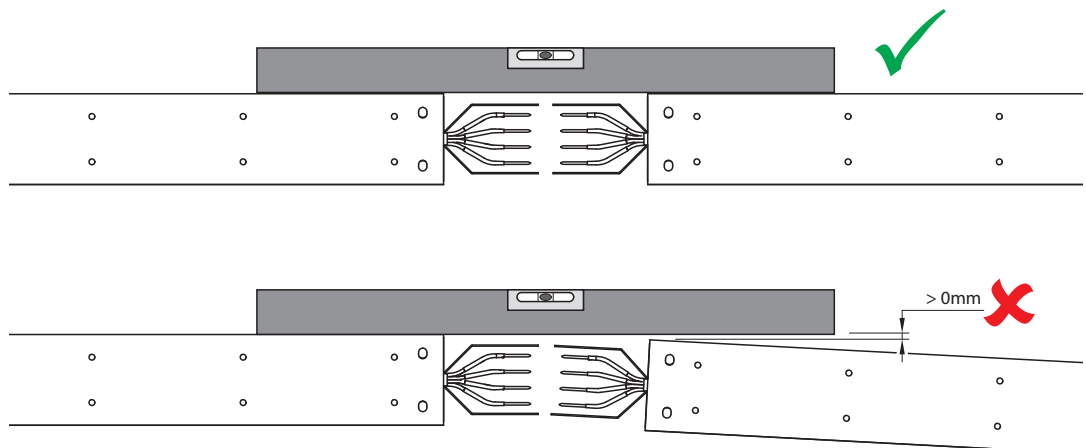

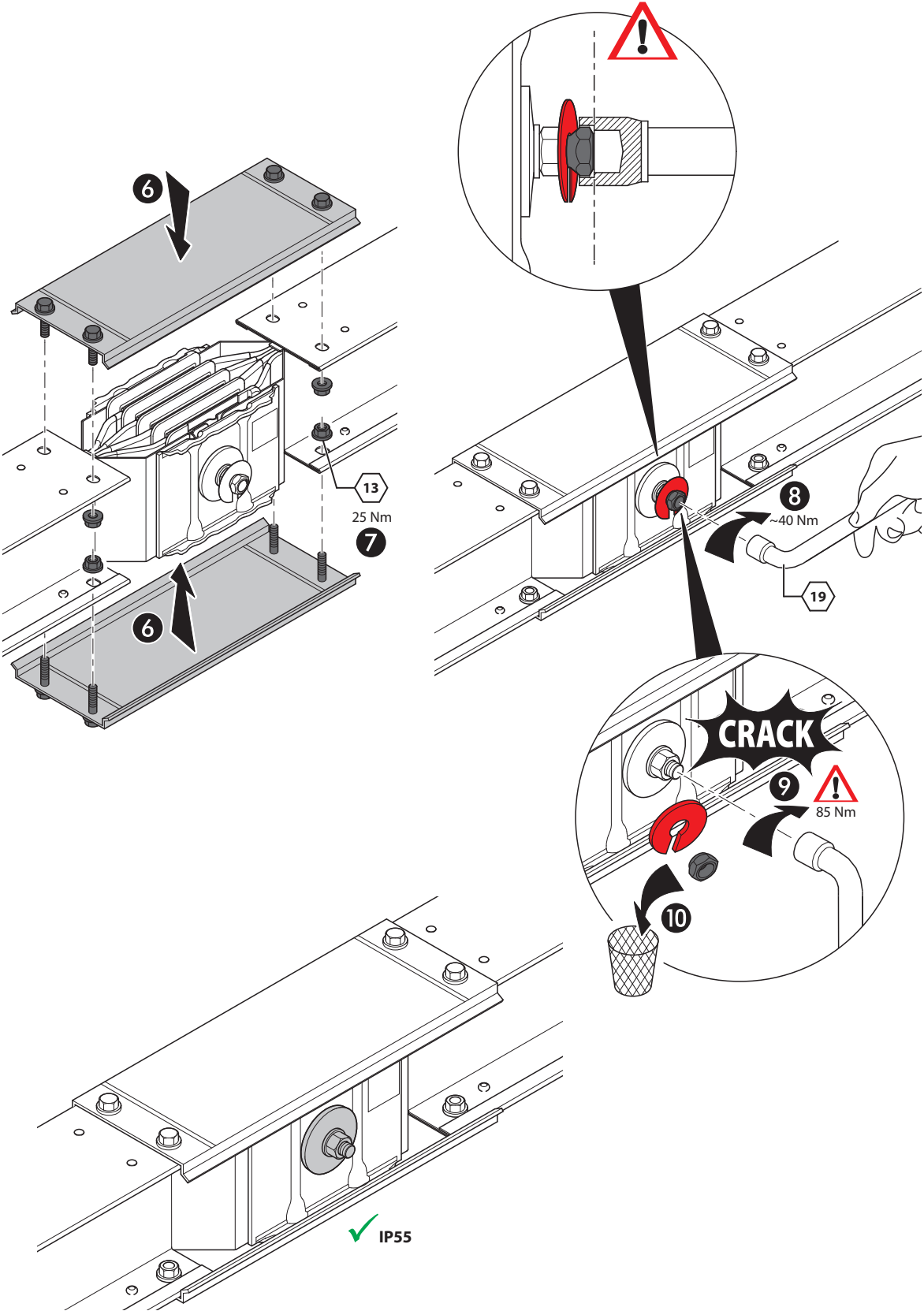

# ZUCCHINI

In case of multi-bolt busbars, follow the sequence below

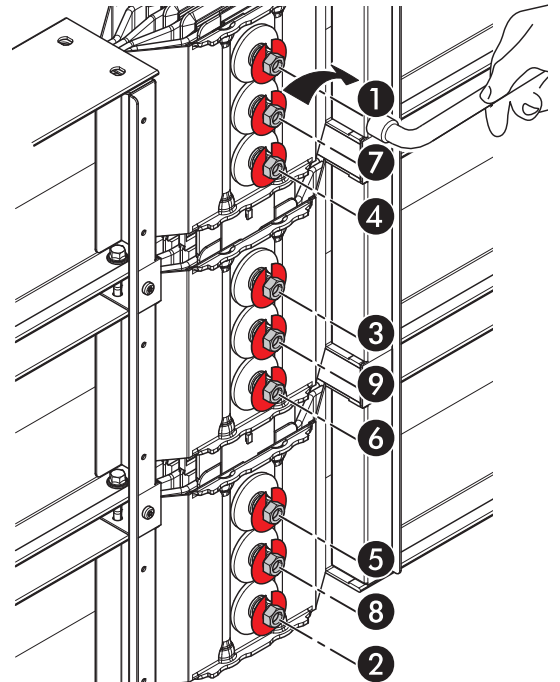
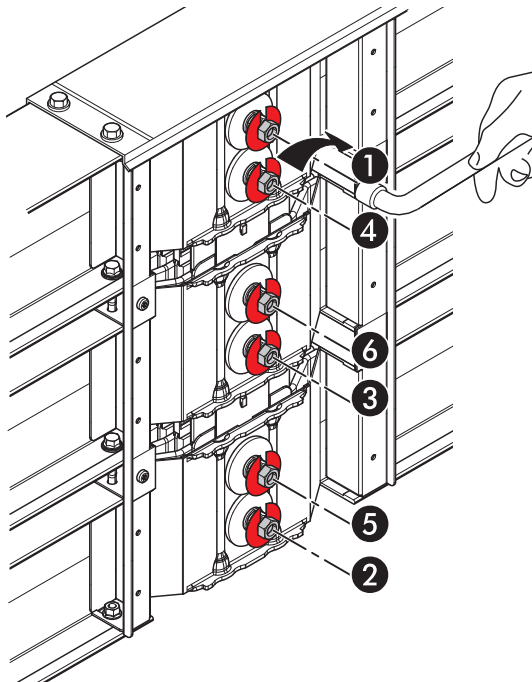
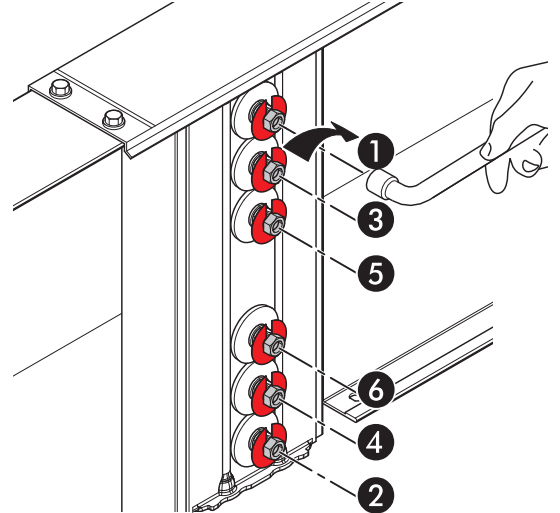
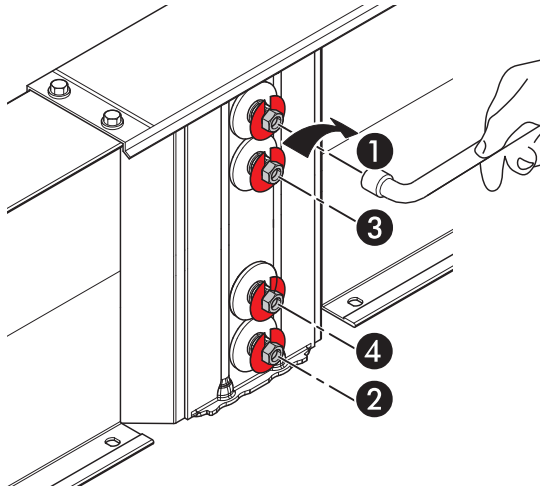
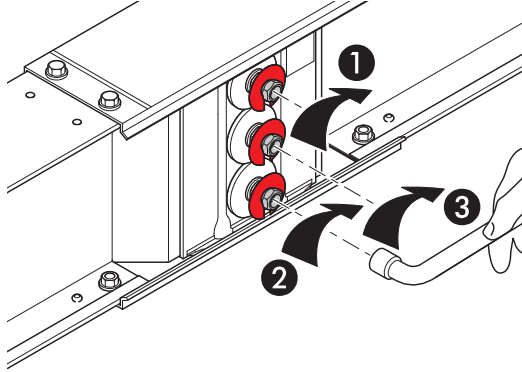

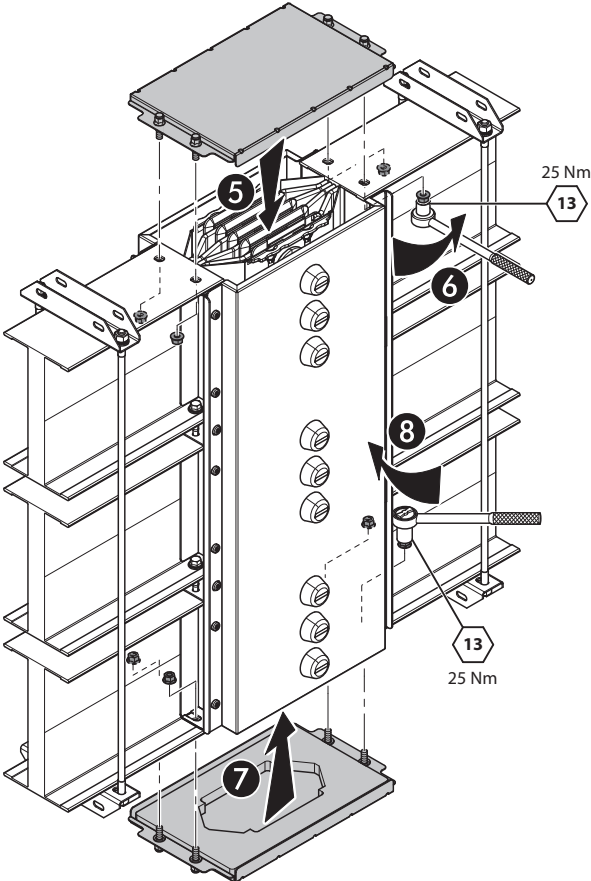
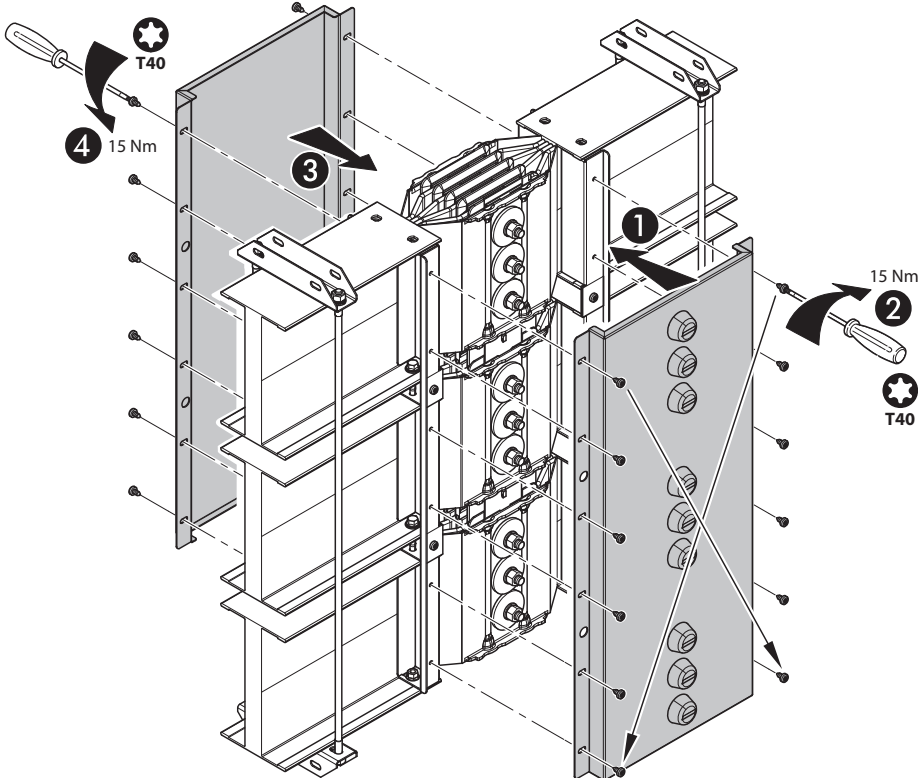

# ZUCCHINI

## 3.3.6 Fire barrier installation

Fire barrier sizes.  
Dimension H  
changes  
with the rating; it  
is specified in the  
technical  
information.

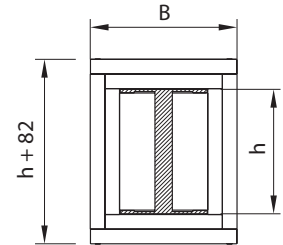
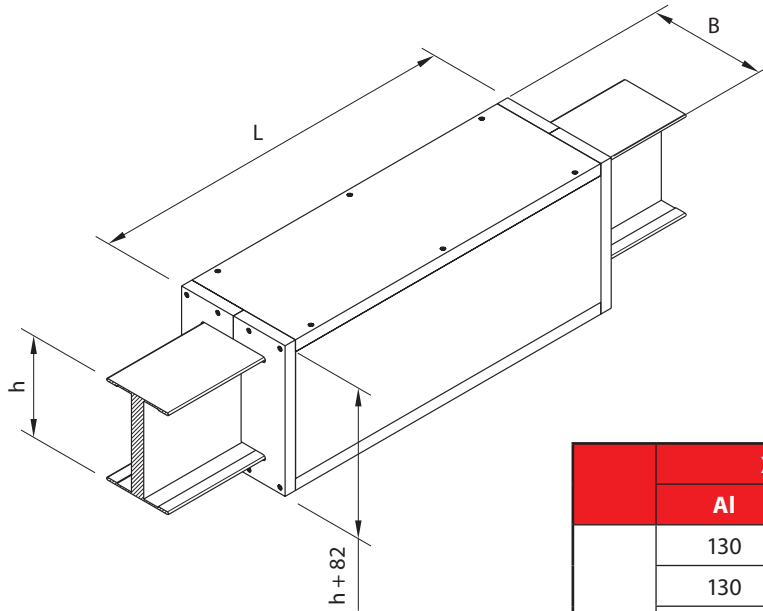

	XCP-S		XCP-HP	
	Al	Cu	Al	Cu
<b>h</b>	130	130	130	130
	130	130	130	130
	130	130	130	130
	170	170	130	170
	200	200	200	170
	220	300	220	220
	380	380	380	380
	440	440	440	440
	480	480	480	480
	590	590	740	680



In order to ensure the maximum resistance class, for some ratings it is also necessary to fit at the factory an internal fire barrier following the indications on the table.  
It is therefore necessary to indicate at the order stage what elements will cross fire resistant walls or ceilings.

The external fire barrier can be used on any trunking component in compliance with the operating instructions specified in figures 1 and 2.

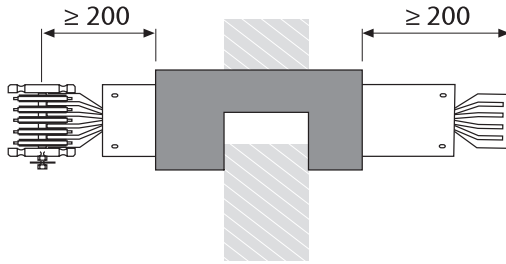

Fig. 1

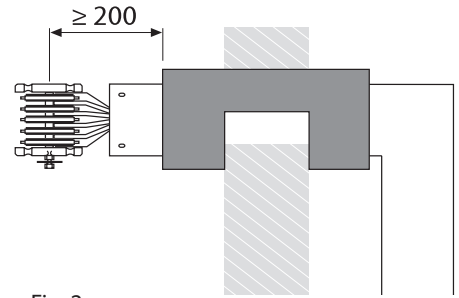

Fig. 2

	USE OF INTERNAL BARRIER			
	Al		Cu	
	Rating (A)	Internal	In (A)	Internal
<b>XCP-S</b>	630-800	√*	800-1000	√*
	1000-2000	-	1250-2000	-
	2500-4000	-	2500-5000	-
	5000	√*	6300	√*
<b>XCP-HP</b>	630-2000	-	800	√*
	2500-4000	-	1000-2500	-
	5000	√*	3200-5000	-
	-	-	6300	√*

Label present on elements containing the internal fire barrier.

**Barriera tagliafiamma**  
**Brandschotte**  
**Coupe-feu**  
**Corta-flama**  
**Firebarrier**

# ZUCCHINI

## 3.3.7 Panel end cap installation



### WARNING

Before drilling, make sure to retrieve the dimensions of the connection flange for the UB to be installed.  
Sample dimensions to be obtained prior to installation.

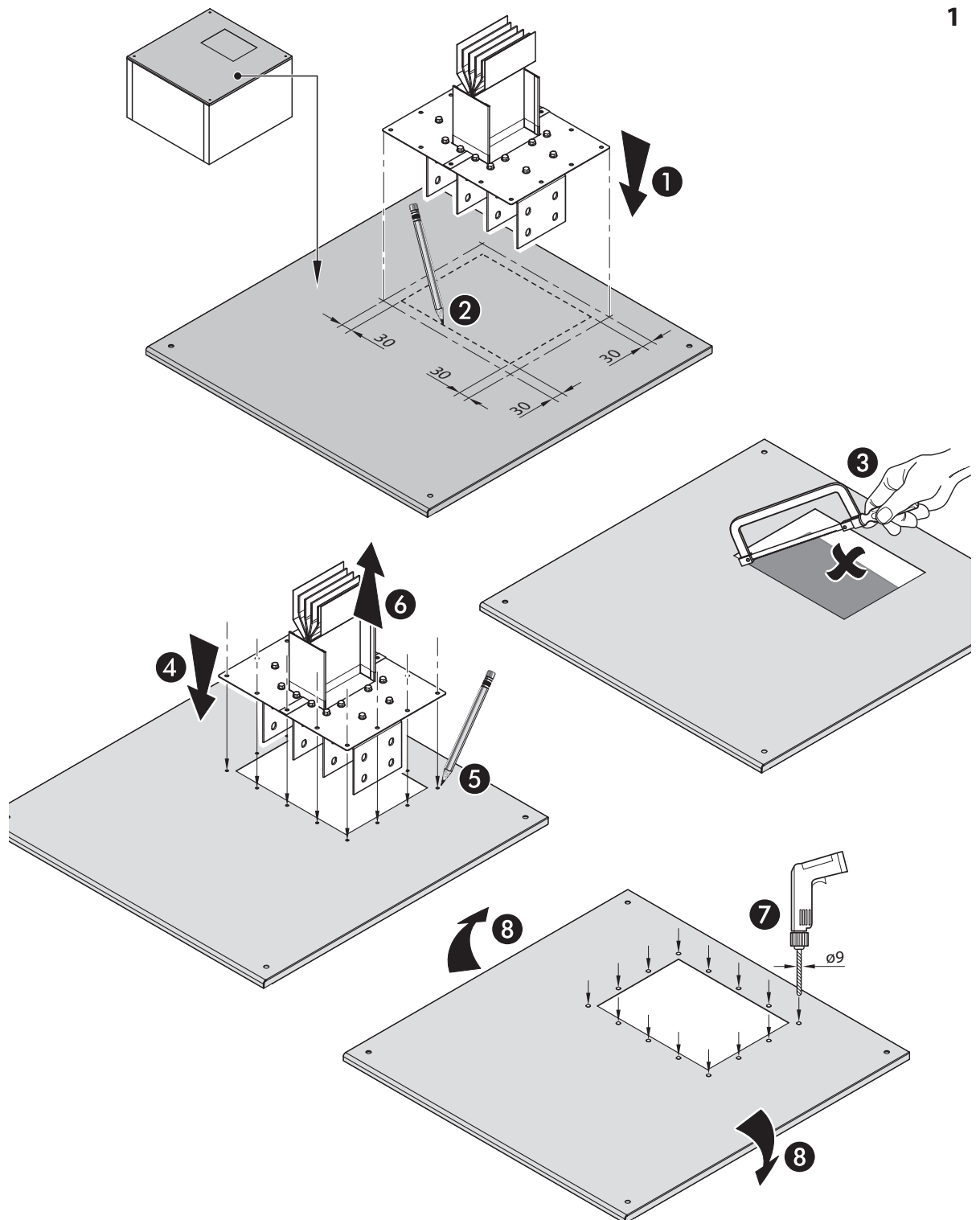

Insert reinforcements (not provided) to strengthen the structure of the electrical panel.

2

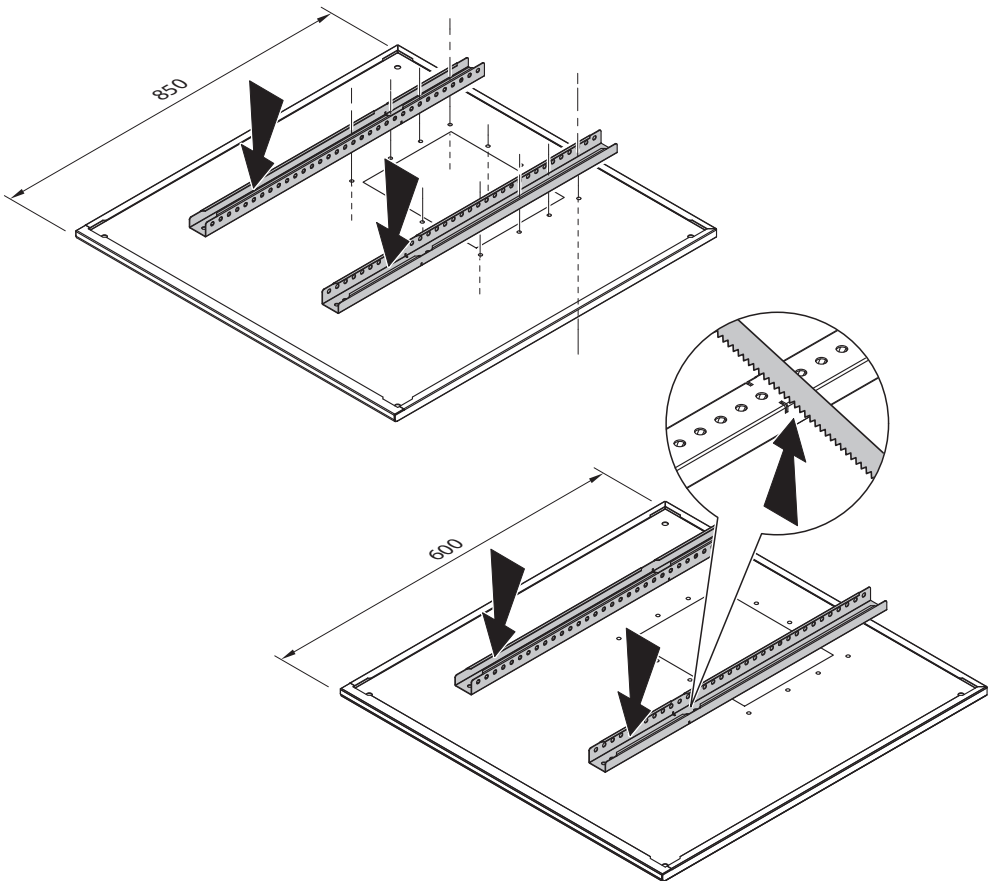

3

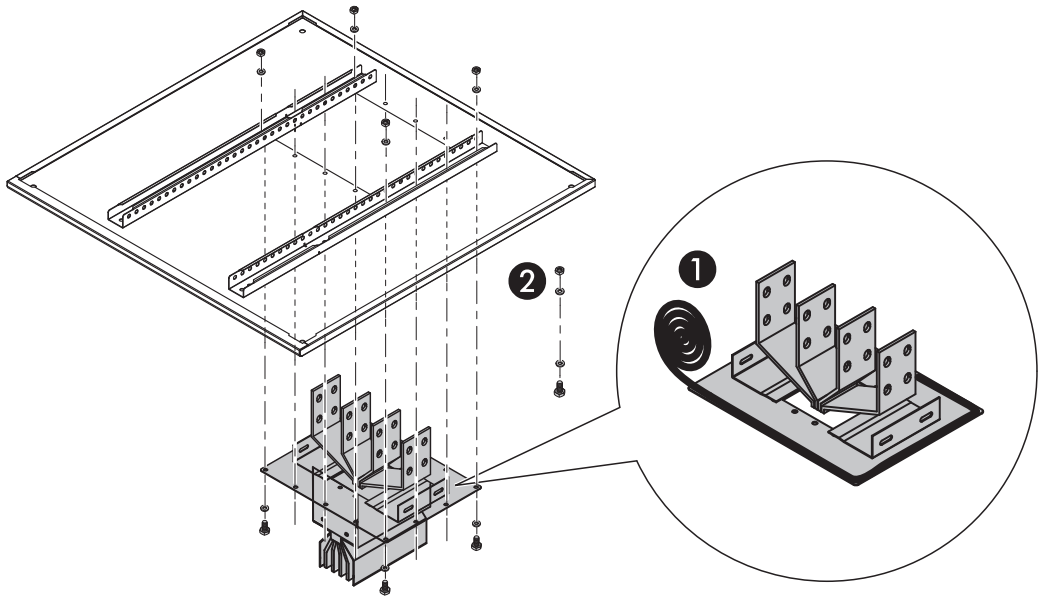

# ZUCCHINI

## Installation of the Feed unit

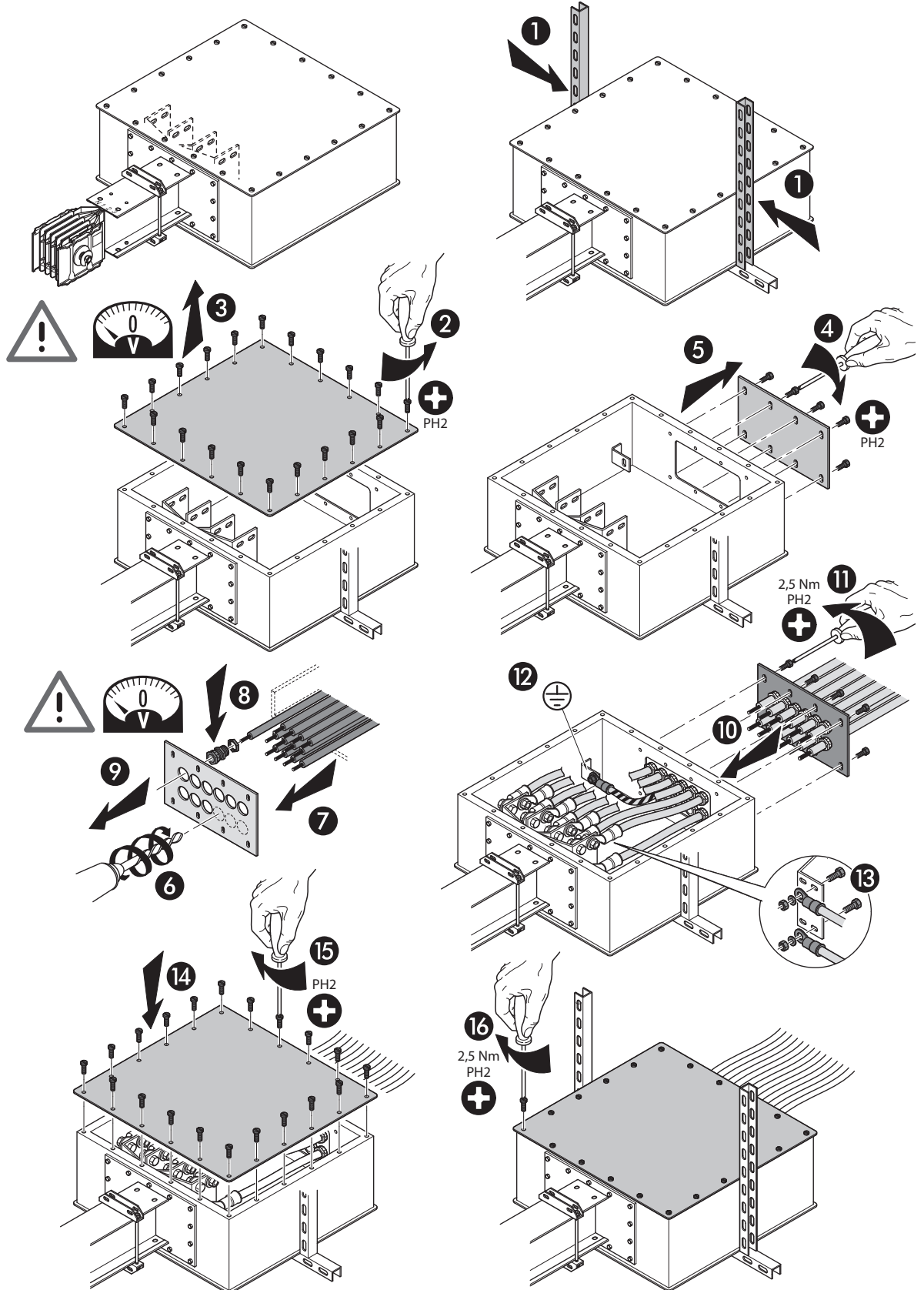

**WARNING**

Before installing the TOB on the busbar, carefully consult the installation instructions related to the TOB.

**When there are tap-off units along the busbars, the minimum distances depend on the dimensions of the tap-offs selected.**

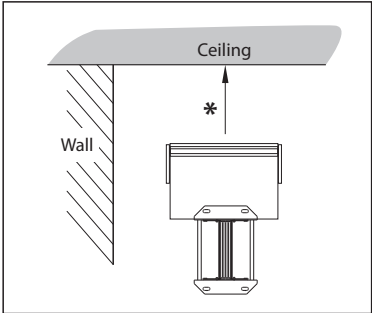

*\* When there is a tap-off box installed above the busbar, check the overall dimension of the open cover of the tap-off unit used in the specific section.*

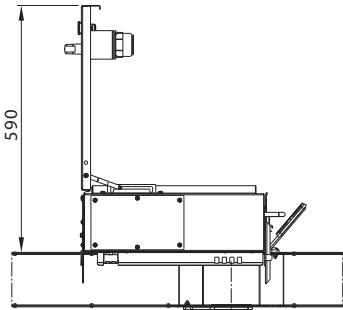

SIZE 1

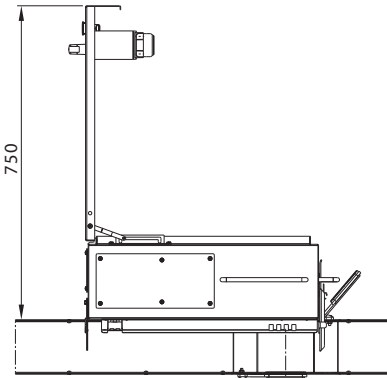
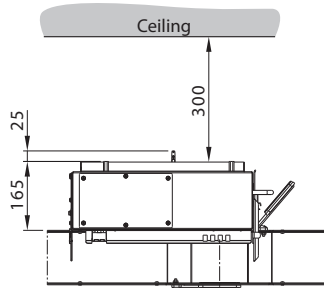

SIZE 2

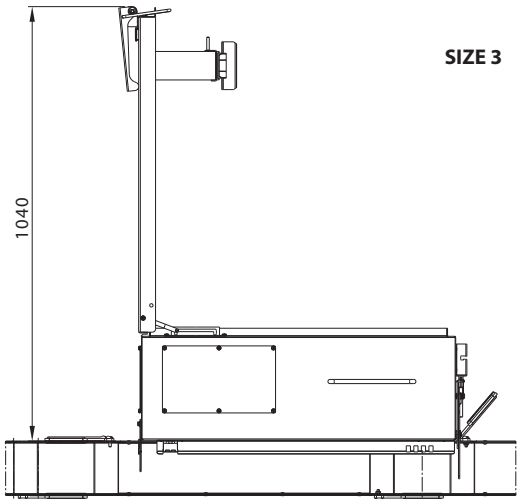
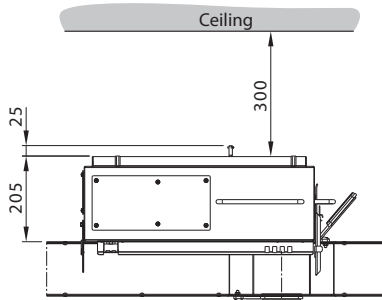

SIZE 3

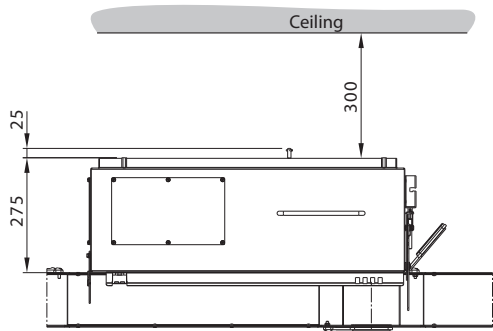

# ZUCCHINI

---

## Fiberglass Plastic TOB overall dimension

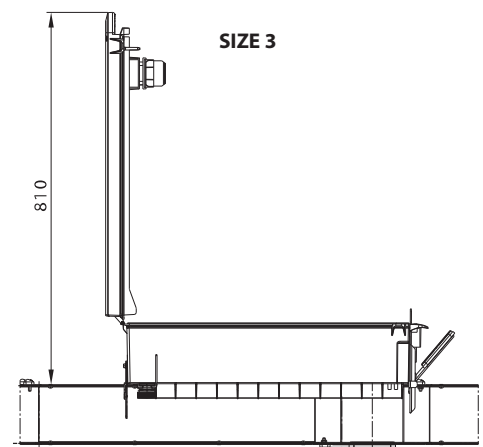
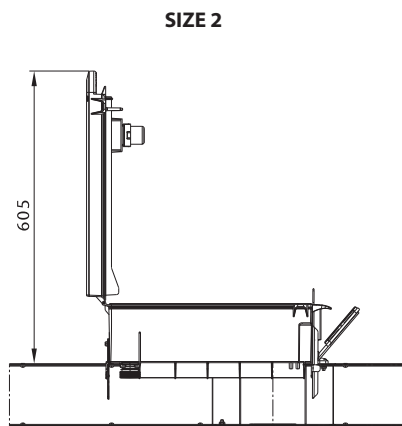
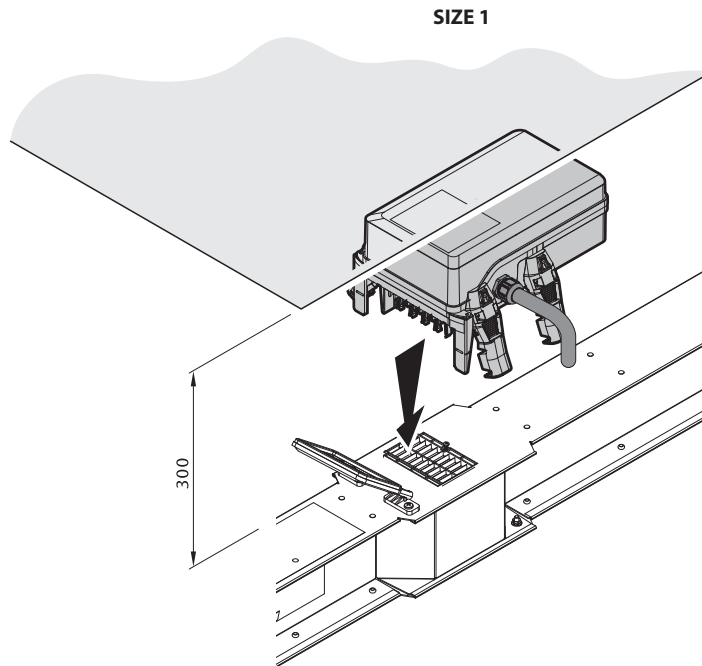

TOB on the Junction: bolt-on type

**Type 4 / Type 5**

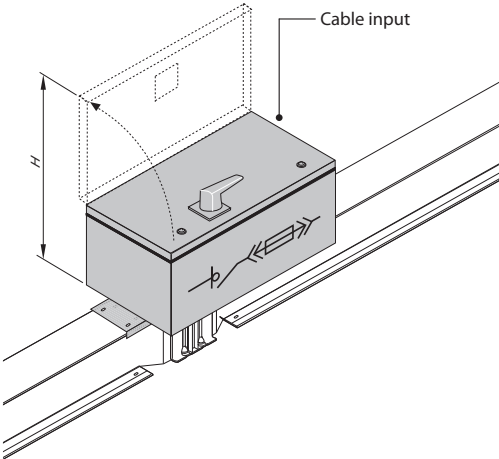

Type	Rating (A)	H
4A	125	630
	250	
	400	
4B	630	675
4C	800	745
	1000	
	1250	

**Type 5 - from 125 A to 1250 A**

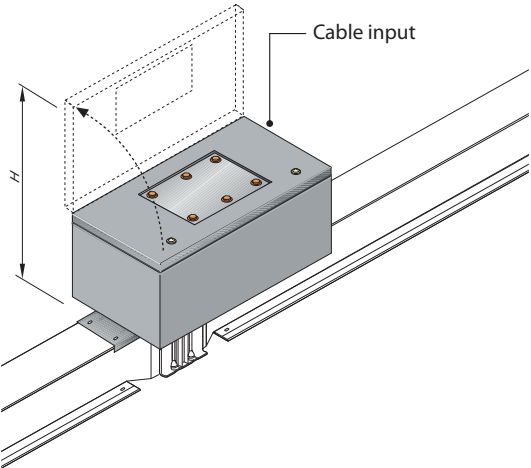

Type	Rating (A)	H
5A	125	630
	250	
	400	
5B	630	675
5C	800	745
	1000	
	1250	

# ZUCCHINI

## 3.3.8 End caps

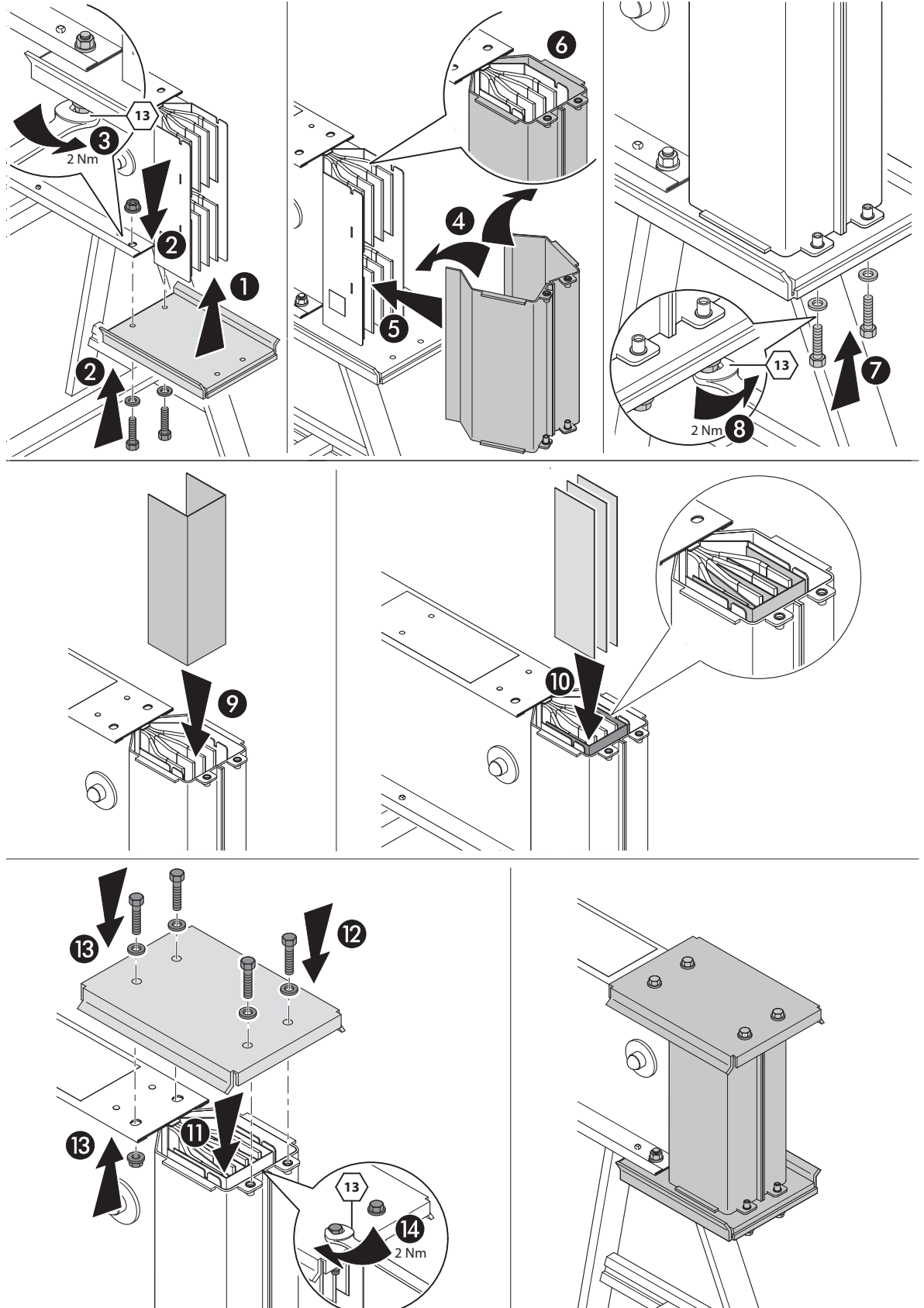



## 4. Commissioning

### 4.1 Busbar Pre-energising Checks

#### 4.1.1 Busbar Installation

- Once the installation is complete, verify that the neutral position and, if present, the functional earth are consistent throughout the entire length of the line (pay particular attention to distribution elements, TEE; transpositions, phase inversions, ATR).
- Check if elements are correctly aligned. If not, align them correctly.
- Use only original accessories of the same product (tap-off boxes, feed unit, etc.).
- Do not step on the busbar.
- Do not cut or drill the busbar (drilling is permitted only to fix supports).
- Do not use the busbar system as a supporting structure for other systems.
- Protect from water, malfunctioning piping, and all fluids that may come from water jets. Cover if necessary. Cap the ends of the busbar joint points that have not been installed after completion of the work.
- Ensure that the system is installed in an environment suitable for the protection degree (IP) of the busbar.
- If during the installation of the TOB, a damaged outlet is noticed, install the TOB in another outlet. If this damage could compromise the IP protection rating, contact customer care.
- It is possible to fix anomalies on painting and slight damaging which could happen during transporting and installation operation by touching up with spray paint (not supplied). We recommend you clean the surfaces with a dry cloth in advance where the painting process will be.
- SWITCHBOARD CONNECTION
  - On switchboard connections verify that the air distances between bars with different potentials are over 40 mm wide. If it is not the case, contact Legrand.
  - Use the standard torque values for the screws to ensure proper fastening. See the following torque for 8.8 screws: 25 Nm for M8 and 50 Nm for M10 85 Nm for M12, 100 Nm for M14, 120 Nm for M16.

#### 4.1.2 Electrical Safety Tests

- Carry out all tests described in the applicable technical installation standard, such as the insulation test between phases neutral and to earth at 1000V with a minimum value of  $1M\Omega$ , for every line stretch. Make sure that no protective/metering device (switch, connector, metering central, etc.) is connected to the system and that the earth-neutral line is separate. All tap-off boxes on the line must be open, removed or with breaker in OFF position (load disconnected). Keep in mind that the results can vary according to the busbar length, width, or number of bars. The results may also vary according to the moisture content. If the insulation value is lower than  $1M\Omega$ , it is necessary to verify the plant completely, starting from the insulating parts of each monobloc. If the insulation is still inadequate, divide the plant into two parts and verify the single stretch to identify the element with low insulation. Continue the splitting if the insulation keeps being inadequate. If the insulation test is made on the single element, the minimal value is  $100M\Omega$  (to ensure an additional level of safety, we use a higher resistance value than the minimum required by the standard, which specifies  $1M\Omega$  for a test voltage of 1000V).

#### 4.1.3 Electric Checks

- In case of energizing the line for the first time, it is better to have experienced personnel present, and if a short circuit is detected, it is mandatory not to energize the line to avoid possible serious accidents.
- In case of excessive noise and vibrations, pay attention as they may indicate installation or product issues.
- If spark formation is noticed along the line, immediately shut down the line and contact support.
- Do not overload the line by exceeding the nominal current.
- Thermal Test on the line: Supply the busbar with a suitable load (suggested at least 40%) and let it work until thermal steady state is reached, then carry out a thermal test. Stick labels on the hottest parts and mark them with progressive numbers to identify the element. Carry out the thermal test again on the labels. Fill the attached form with the measured values, together with ambient temperature and working current. Thermal tests can be carried out with contact temperature sensors, optical pyrometers, or thermal cameras. The temperature-rise measured on junctions casing, once the installation is completed and working with a maximum ambient temperature of  $50/55^{\circ}\text{C}$  (for aluminium/copper conductors respectively), must not exceed  $70^{\circ}\text{K}$  (calculated as absolute temperature minus nearby ambient temperature). In case of problems, contact Legrand.
- If quality control requests a torque verification of the monobloc bolts after the thermal test, it has to be guaranteed at least 60Nm.
- Thermal Test on Plug-in: Carry out a thermal test on the cover near the lock, using contact temperature sensors, optical pyrometers, or thermal cameras. The test has to be carried out with tap-off boxes running with a suitable current (suggested at least 40%) and let it work until thermal steady state is reached.

Fill in the attached form together with ambient temperature and working current.

# ZUCCHINI

---

## 4.2 Filling the check form

### 4.2.1 Busduct record form for inspections and controls

PLANT	
CLIENT	
CONFIRMATION OF ORDER N.	
MANUFACTURING YEAR	
INSTALLATION YEAR	
INSTALLING COMPANY	

### 4.2.2 Inspections after installation

PERSON IN CHARGE OF INSPECTIONS	
COMPANY (if different from installing company)	
INSPECTION DATE	
SIGNATURE	

Element alignment	YES	NO
-------------------	-----	----

#### Junctions

Checked junctions (quantity)		
Total junctions (quantity)		
Correct installation	YES	NO
Soundness of insulating parts	YES	NO
Correct centring	YES	NO
Correct coupling clamp (85 Nm) - write value		

#### Connection to switchboard

Correct air distance between bars	
Correct coupling clamp	

#### Tests on electrical safety

Insulating resistance between L1 and neutral (L1-N)	
Insulating resistance between L2 and neutral (L2-N)	
Insulating resistance between L3 and neutral (L3-N)	
Insulating resistance between L1 and L2 (L1-L2)	
Insulating resistance between L2 and L3 (L2-L3)	
Insulating resistance between L3 and L1 (L3-L1)	
Insulating resistance between L1 and earth (L1-PE)	
Insulating resistance between L2 and earth (L2-PE)	
Insulating resistance between L3 and earth (L3-PE)	
Insulating resistance between neutral and earth (N-PE)	
Test voltage	

#### Note

N.B. Write the measured value of the insulating resistance

#### Thermal tests

Fill in the attached table, with reference to the inspected element.

As per the measurement point and the plate present on the measurement side, fill in the relative box with the measured temperature value.

## 5. Verification

### 5.1 Busbar Periodic Inspections

- Technically, busbar systems do not require maintenance. However, annual inspections are recommended to identify any conditions that might negatively affect their performance depending on the environmental conditions in which they are used.

#### 5.1.1 Inspection Actions

##### Visual inspection on the line:

- **Moisture and Liquid Leaks:** Busbar systems should not be exposed to moisture, process vapours, and liquid leaks (e.g., roof leakage). In case of any dripping or moisture on the busbar pieces, take necessary precautions without delay and eliminate the causes. After relevant checks, replace the busbar piece if necessary.
- **External material:** Ensure there is no accumulation of dust, soil, mortar, etc., on the busbar systems. Clean any detected accumulation.
- **Cleaning Agents:** Avoid using cleaning aggressive agents or other materials containing hydrocarbons during installation, operation, or maintenance, as they may harm plastic components and metal casings.

##### Visual inspection

- Check the alignment of the bolt marks (if any) and perform a spot check of the temperatures to ensure there are no significant deviations between adjacent junctions. If a problem is noticed with the junction, proceed to an inspection.

##### Thermal inspection

- Daily Line Operation Check
- Verify the line during its normal daily operation. If this is the first inspection after commissioning, proceed as follows:
- If the load conditions differ significantly from those during commissioning, check the temperatures according to the procedure defined during the commissioning phase (see section 4.1.3).
- If the operating conditions are similar to those recorded during commissioning, ensure that there is no temperature rise exceeding 15 K.
- For all inspections following the initial one, the rule remains to ensure that there is no temperature difference exceeding 15 K. Carry out the thermal test again on the labels. Fill the attached form with the measured values, together with ambient temperature and working current. Thermal tests can be carried out with contact temperature sensors, optical pyrometers, or thermal cameras. **In case any anomalies occur, proceed with the following steps:**
  - Unload and de-energize the busbar, allowing at least 2 hours for cooling. Open the connection covers and verify that: Plastics are in good condition (no slits) and plastic colour has not changed. There is no water, or foreign materials (dust, grime, etc.). Blocks correctly adhere to bars, i.e., conducting parts fully make contact.
  - Check the connection using a torque-wrench. During measurement, the line must be at ambient temperature. If the torque moment is lower than 60Nm, re-establish it.

#### 5.1.2 Busbar Periodic Inspections

- Busduct periodic inspections on tap-off boxes, to be carried out yearly. Legrand XCP busbar when designed and installed by Legrand group, it's only recommended periodical yearly inspections to be carried out following these guidelines:

### 5.2 Thermal and Visual Inspection of TOBs

- Visual inspection of tap-off boxes. Checking the alignment of the fixing bolt marks (if any) and verifying that the TOB is mechanically stable without dust or water. If you notice a problem, proceed to a thermal inspection on the cover near the locks.
- Registration of temperature together with ambient temperature and working current for each TOB
- In case of abnormal temperature values versus initial ones, specific actions have to be carried out by trained personnel:
  - Switch off the load connected to the TOB under analysis.
  - Verify the brackets screws, that fix the TOB on the busduct, are correctly tightened.
  - Open the cover and verify that:
    - Plastics are in good condition (no slits) and plastic colour has not changed
    - There are no water, scale-marks or foreign materials (dust, grimes...)
    - Insulating protections correctly cover the live parts and connection bars for clamps (if present) are in good conditions, without any signs of wear.
  - Check all connections for cables using a torque-wrench.
  - verify the breaker or fuse holder (if present) don't show signs of overheating or damages.

After completing all the indicated checks and necessary restorations, proceed with energizing the line and verifying the temperature of the checked points, fill in the attached form together with ambient temperature and working current. If the measured relative temperature ( $\Delta T$ ) is abnormal compared to the temperature measured during installation, contact customer care.

# ZUCCHINI

---

## 5.2.1 Annual periodic inspections carried out one year after energizing and every other following year

PERSON IN CHARGE OF INSPECTIONS	
COMPANY (if different from installing company)	
INSPECTION DATE	
SIGNATURE	

### Junctions

Checked junctions (quantity)		
Total junctions (quantity)		
Soundness of insulating parts	YES	NO
Absence of water, scale and dust in flanges	YES	NO
Correct centring	YES	NO
Correct coupling clamp (85 Nm) - write value		

### Connection to switchboard

Correct air distance between bars	
Correct coupling clamp	
Tests on electrical safety	
Insulating resistance between L1 and neutral (L1-N)	
Insulating resistance between L2 and neutral (L2-N)	
Insulating resistance between L3 and neutral (L3-N)	
Insulating resistance between L1 and L2 (L1-L2)	
Insulating resistance between L2 and L3 (L2-L3)	
Insulating resistance between L3 and L1 (L3-L1)	
Insulating resistance between L1 and earth (L1-PE)	
Insulating resistance between L2 and earth (L2-PE)	
Insulating resistance between L3 and earth (L3-PE)	
Insulating resistance between neutral and earth (N-PE)	

### Note

N.B. Write the measured value of the insulating resistance

### Thermal tests

Fill in the attached table, with reference to the inspected element.

As per the measurement point and the plate present on the measurement side, fill in the relative box with the measured temperature value.

## 5.2.2 Inspections after installation and yearly

<b>PERSON IN CHARGE OF INSPECTIONS</b>	
<b>COMPANY (if different from installing company)</b>	
<b>INSPECTION DATE</b>	
<b>SIGNATURE</b>	

Correct coupling clamp of connecting screws

### Thermal tests

<b>Tap-off box n.</b>	<b>Measured T</b>	Ambient T	Dt	Ib
<b>Tap-off box n.</b>	<b>Measured T</b>	Ambient T	Dt	Ib
<b>Tap-off box n.</b>	<b>Measured T</b>	Ambient T	Dt	Ib
<b>Tap-off box n.</b>	<b>Measured T</b>	Ambient T	Dt	Ib
<b>Tap-off box n.</b>	<b>Measured T</b>	Ambient T	Dt	Ib
<b>Tap-off box n.</b>	<b>Measured T</b>	Ambient T	Dt	Ib
<b>Tap-off box n.</b>	<b>Measured T</b>	Ambient T	Dt	Ib
<b>Tap-off box n.</b>	<b>Measured T</b>	Ambient T	Dt	Ib
<b>Tap-off box n.</b>	<b>Measured T</b>	Ambient T	Dt	Ib
<b>Tap-off box n.</b>	<b>Measured T</b>	Ambient T	Dt	Ib
<b>Tap-off box n.</b>	<b>Measured T</b>	Ambient T	Dt	Ib
<b>Tap-off box n.</b>	<b>Measured T</b>	Ambient T	Dt	Ib

Dt = T<sub>measured</sub> - T<sub>ambient</sub>

Ib = working current

# ZUCCHINI

## 5.2.3 Feeder element

<b>ELEMENT IDENTIFICATION</b>	
<b>PERSON IN CHARGE OF INSPECTIONS</b>	
<b>COMPANY (if different from installing company)</b>	
<b>INSPECTION DATE</b>	
<b>SIGNATURE</b>	

N.B. Stick on the element a label with a progressive number for identification.

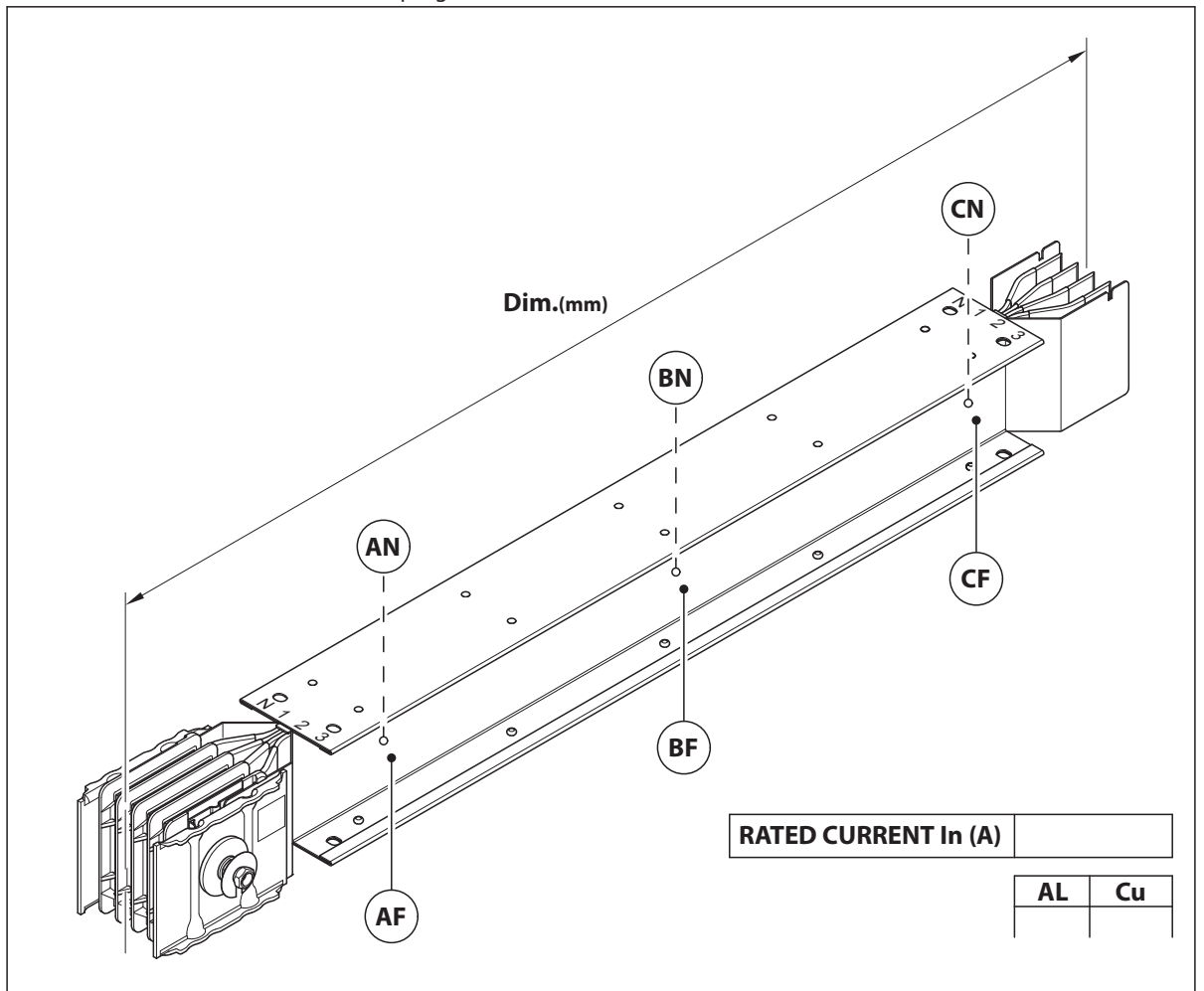

POS.	Dim.(mm)	AF	BF	CF	AN	BN	CN	Ta (°C)	I. (A)

5.2.4 Dihedral elbow

ELEMENT IDENTIFICATION	
PERSON IN CHARGE OF INSPECTIONS	
COMPANY (if different from installing company)	
INSPECTION DATE	
SIGNATURE	

N.B. Stick on the element a label with a progressive number for identification.

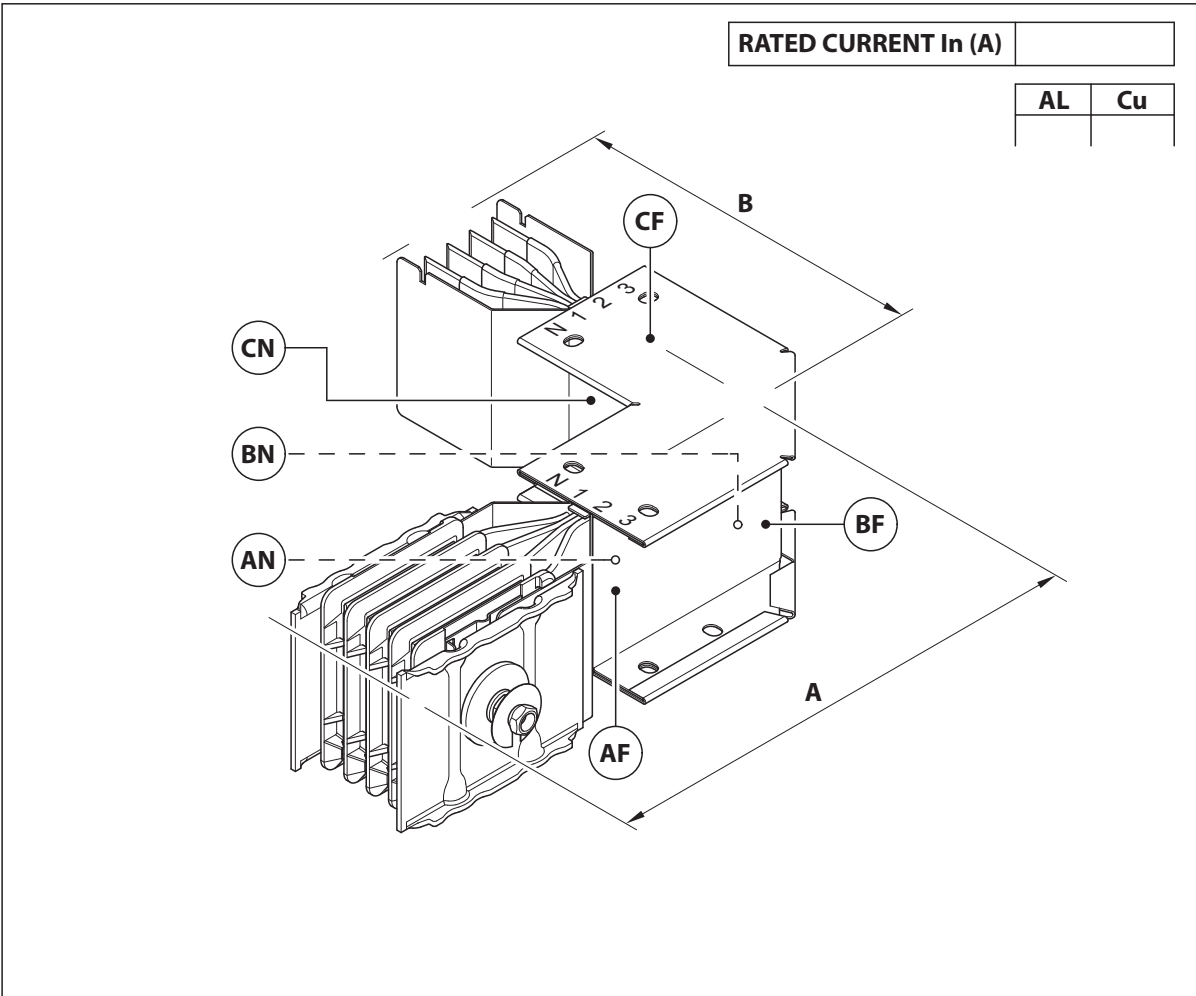

POS.	Dim.(mm) A	Dim.(mm) B	AF	BF	CF	AN	BN	CN	Ta (°C)	I. (A)

# ZUCCHINI

## 5.2.5 Flat elbow

<b>ELEMENT IDENTIFICATION</b>	
<b>PERSON IN CHARGE OF INSPECTIONS</b>	
<b>COMPANY (if different from installing company)</b>	
<b>INSPECTION DATE</b>	
<b>SIGNATURE</b>	

N.B. Stick on the element a label with a progressive number for identification.

<b>RATED CURRENT I<sub>n</sub> (A)</b>		
<b>AL</b>	<b>Cu</b>	

POS.	Dim.(mm) A	Dim.(mm) B	AF	BF	CF	AN	BN	CN	Ta (°C)	I. (A)



**5.2.6 Troubleshooting table**

Problem's signals	Where?	Causes:	Solutions:	
			Materials are damaged:	Materials are ok:
Abnormal heat on:	Monoblock or along busbar plant or elbow	Couple loosening Nut not broken	Request spare parts	Strengthen the torque
		Wrong mounting Monoblock tooth wrong		Change way to mounting
Burnished point on:	casing or insulating	broken insulating overload on the line	request spare parts	
Low insulating measure	apply "half plant" technique, to find out:	mechanical damage water inside broken insulating	request spare parts	
Mccb break on panel board, on feed unit, on TOB:	apply "half plant" technique, to find out:	<ul style="list-style-type: none"> <li>- electrical overload</li> <li>- bad electrical contact</li> <li>- short circuit on load</li> <li>- short circuit inside TOB</li> <li>- broken MCCB</li> <li>- wrong mounting MCCB</li> <li>- too much hot environment</li> <li>- water inside</li> </ul>	request spare parts	

**6. Disposal**

For the identification of the materials and the disposal instructions visit [www.bticino.com/disposal](http://www.bticino.com/disposal).

# ZUCCHINI

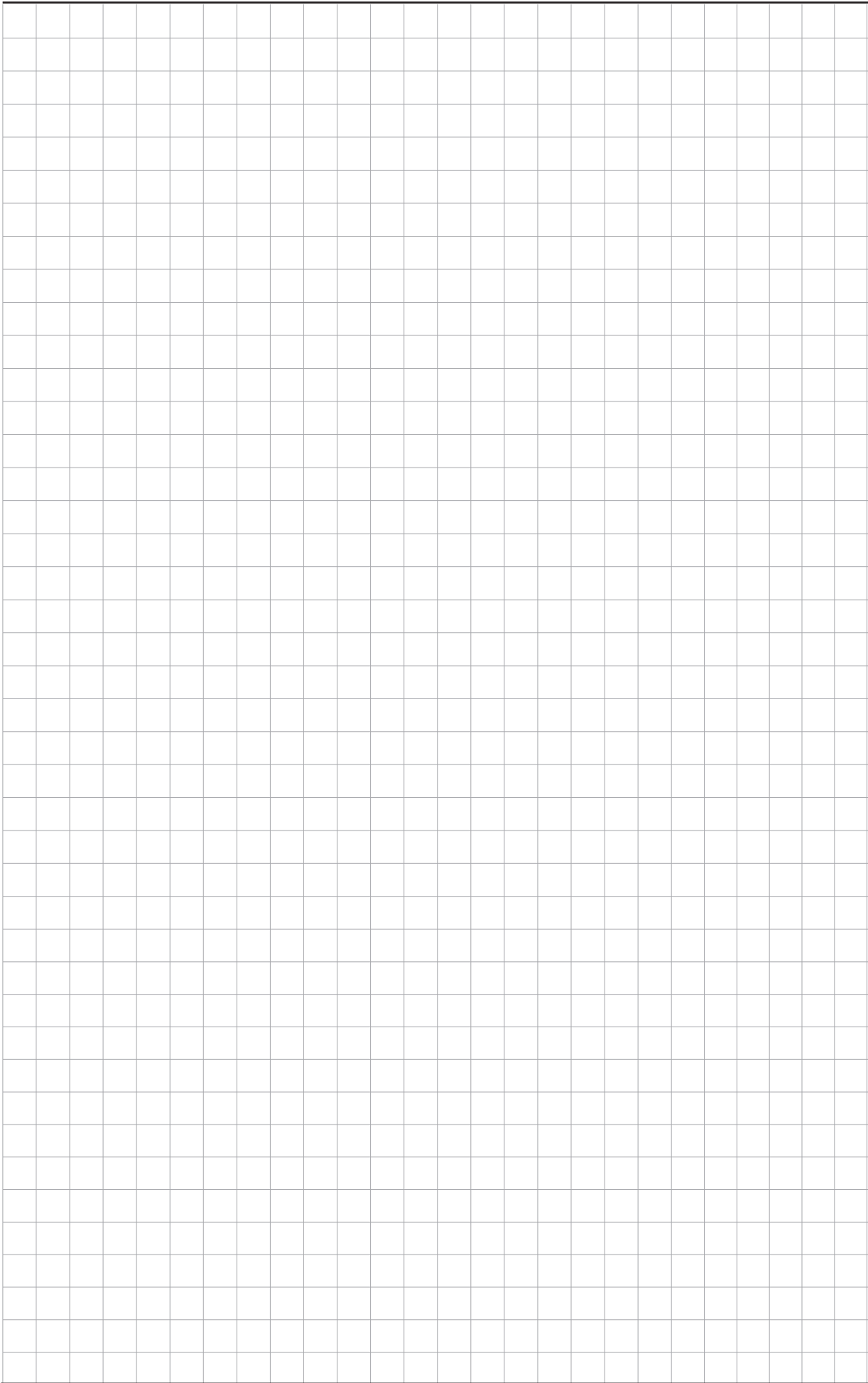



# ZUCCHINI

Legrand:  
LEGRAND  
Pro and Consumer Service  
BP 30076 - 87002  
LIMOGES CEDEX FRANCE  
[www.legrand.com](http://www.legrand.com)

Installer stamp